

COPYRIGHT 1942 BY FORD MOTOR COMPANY, DEARBORN, MICHIGAN

PARTS PRICE LIST

JAN. 2, 1942

**Sold and Distributed by
FERGUSON-SHERMAN MANUFACTURING CORPORATION
DEARBORN, MICHIGAN**

FORD TRACTOR

with

Ferguson System

PARTS PRICE LIST

EFFECTIVE JAN. 2, 1942

Copyright 1942
Ferguson-Sherman Mfg. Corp.
Dearborn, Michigan
All rights reserved

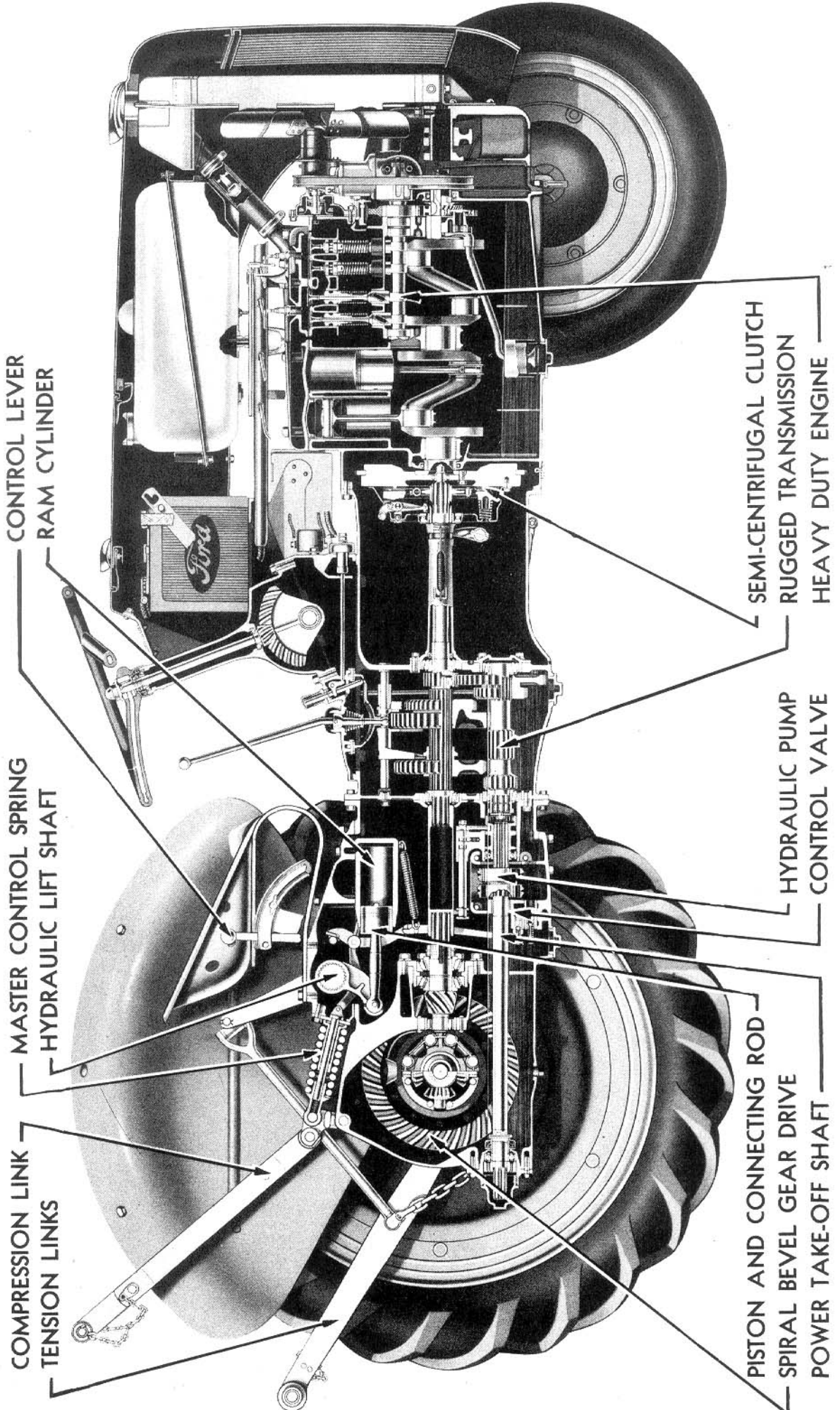

CONTROL LEVER
RAM CYLINDER

SEMI-CENTRIFUGAL CLUTCH
RUGGED TRANSMISSION
HEAVY DUTY ENGINE

MASTER CONTROL SPRING
HYDRAULIC LIFT SHAFT

HYDRAULIC PUMP
CONTROL VALVE

COMPRESSION LINK
TENSION LINKS

PISTON AND CONNECTING ROD
SPIRAL BEVEL GEAR DRIVE
POWER TAKE-OFF SHAFT

INDEX

	Page
ACCESSORIES	40
AIR CLEANER	31-32
AMMETER	35
AXLE - FRONT	14-16
AXLE - REAR	17-20
BATTERY	35
BRAKES	13
CARBURETOR	30-31
DISTRIBUTOR AND COIL	36-37
DRAWBAR	20
ENGINE	21-23
FENDER	38
FUEL SYSTEM	30
GENERATOR	32-35
GOVERNOR	39
HEAD LAMP	40
HOOD ASSEMBLY	38
HYDRAULIC LIFT	5-9
HYDRAULIC PUMP	9
MANIFOLD	30
MUFFLER ASSEMBLY	20
OIL FILTER	39-40
POWER TAKE-OFF PULLEY (ATTACHMENT)	9-11
RADIATOR AND GRILLE	27
SEAT - DRIVERS	5
STANDARD PARTS	41-44
STARTER AND DRIVE	35-36
STEERING GEAR	16-17
THROTTLE CONTROLS	32
TOOL BOX AND TOOLS	39
TRANSMISSION	23-27
WATER PUMP	27-30
WHEELS AND WHEEL HUBS	11-12
WIRING	37

INSTRUCTIONS FOR ORDERING PARTS

1. Always give tractor number when requested in foot notes. The number is located on left side of motor block.
2. Always order by part number and name.
3. Part orders should be separate and not included with letters pertaining to other subjects.
4. Specify how shipments are to be made—Freight, Parcel Post, or Express.
5. Order parts through your local distributor.

Prices subject to change without notice

Any and all taxes levied will be added to prices in effect at the time of shipment.

Copyright 1942

FORD TRACTOR PARTS PRICE LIST



Part No.	Price	Part Name	Unit	Year	Remarks
SEAT DRIVERS					
(See Illustration on Page 18)					
9N-400-A	\$ 2.65	Seat Assy. - Drivers (Steel)	1	39-42	
350617-S7-8		Bolt (Carriage)-Seat to Seat Spring	1	39-42	
33792-S7-18		Nut (Hex)-Seat Spring Bolt	1	39-42	
351436-S7-8		Washer (Lock)-Seat to Seat Spring Bolt ..	1	39-42	
9N-404	2.65	Spring-Drivers Seat	1	39-42	
21441-S7		Bolt (Hex Head)-Spring Drivers Seat	2	39-42	
HYDRAULIC LIFT					
(See Illustration on Page 6)					
9N-500	79.00	Hydraulic Lift Assembly	1	39-42	
9N-501	15.35	Cover - Hydraulic Lift	1	39-42	
21447-S7-8		Bolt (Hex Head)-Hydraulic Lift Cover to Center Housing	7	39-42	
21446-S7		Bolt (Hex Head)-Hydraulic Lift Cover to Center Housing	3	39-42	
21449-S7		Bolt (Hex Head)-Hydraulic Lift Cover to Center Housing	4	39-42	
9N-502	.30	Gasket - Hydraulic Lift Cover	1	39-42	
9N-504	2.50	Fork Assy. (Hand Control)-Hydraulic Lift. Pin (Cotter)-Hydraulic Lift Hand Control Fork	2	39-42	
72003-S7-8		Pin (Clevis)-Hydraulic Lift Hand Control Fork	2	39-42	
352592-S		Pin (Clevis)-Hydraulic Lift Hand Control Fork Assy. Center	2	39-42	
352547-S		Pin (Cotter)-Hydraulic Lift Hand Control Fork Assy. Center	2	39-42	
72003-S7-8		Upper Link Pin Chain Assy. - Front, left.	1	39-42	
9N-505	.15	Cylinder - Hydraulic Lift (With 9N-547-A)	1	39-42	Before Tr. #47020 ..
9N-510-A	5.20	Cylinder - Hydraulic Lift (With 9N-547-B)	1	39-42	After Tr. #47019 ..
9N-510-B	5.20	Bolt (Hex Head)-Hydraulic Lift Cylinder to Cover	2	39-42	
20886-S7-8		Bolt (Hex Head)-Hydraulic Lift Cylinder to Cover	2	39-42	
20889-S7		Nut (Hex)-Cylinder to Hydraulic Lift Cover	4	39-42	
33794-S7-8		Control Lever and Friction Plate Assy. Hydraulic Lift	1	39-42	
9N-514	1.75	Quadrant - Hydraulic Lift Control	1	39-42	
9N-515-A	3.75	Bolt (Hex Head)-Hydraulic Lift Control Quadrant to Cover	4	39-42	
20302-S7-8		Washer (Lock)-Hydraulic Lift Control Quadrant to Cover Bolt	4	39-42	
351428-S7-8		Shaft - Hydraulic Lift Control Lever	1	39-42	
9N-517	2.20	Nut (Castle Hex)-Control Lever Arm to Friction Plate	1	39-42	
33817-S		Pin (Cotter)-Control Lever Arm to Friction Plate	1	39-42	
72026-S		Key (Woodruff #6)-Hydraulic Lift Control Lever	1	39-42	
74175-S		Disc (Friction)-Hydraulic Lift Control ..	1	39-42	
9N-518	.05	Retainer - Hydraulic Lift Control Lever .	1	39-42	
9N-520	.35	Stop Assy.-Hydraulic Lift Control Lever .	1	39-42	
9N-521	.25				



FORD TRACTOR PARTS PRICE LIST

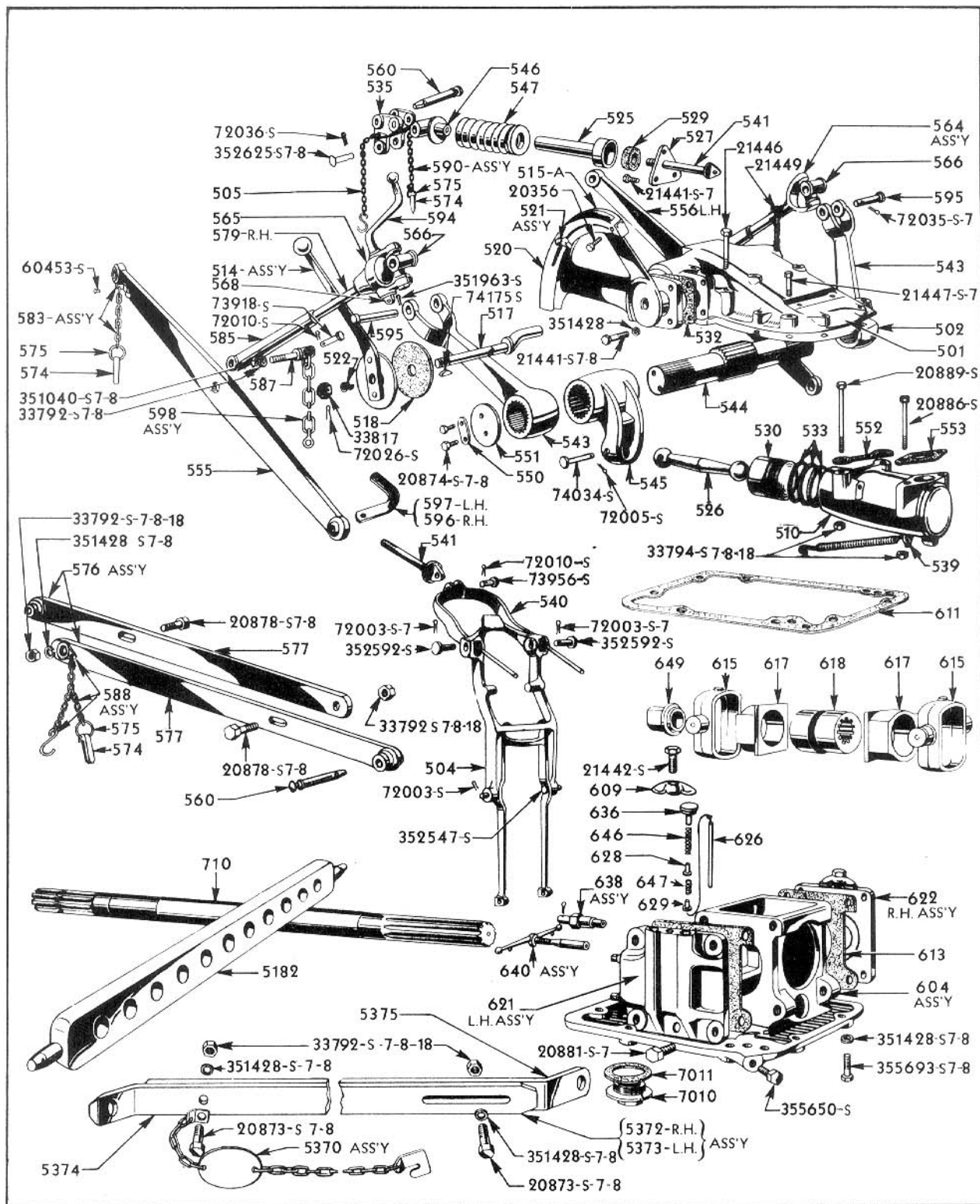

FORD TRACTOR PARTS PRICE LIST



Part No.	Price	Part Name	Unit	Year	Remarks
HYDRAULIC LIFT (CONT'D)					
34745-S7-8		Washer (Stop)-Hydraulic Lift Control Lever	1	39-42	
350923-A-S7-8		Nut (Special Wing) - Hydraulic Lift Control Lever Stop	1	39-42	
9N-522	\$.08	Washer - Hydraulic Lift Control Spring ..	1	39-42	
9N-523-A	.02	Gasket - Lower Link Support (Oval End) ..	2	39-42	
9N-523-B	.02	Gasket - Lower Link Support (Square End) .	2	39-42	
9N-525-B	.45	Spring Seat - Hydraulic Lift	1	39-42	
9N-526	1.35	Connecting Rod - Hydraulic Lift	1	39-42	
74034-S		Pin (Clevis) - Piston Rod	1	39-42	
72005-S		Pin (Cotter) - Piston Rod to Arm Pin	1	39-42	
9N-527	.15	Plate - Hydraulic Lift Cover	1	39-42	
21441-S7		Bolt (Hex-Head) - Hydraulic Lift Cover Plate	3	39-42	
9N-529	.01	Felt - Hydraulic Lift Spring Seat	1	39-42	
9N-530	1.55	Piston - Hydraulic Lift	1	39-42	
9N-531	1.70	Bushing - Hydraulic Lift	2	39-42	
9N-532	.02	Gasket - Hydraulic Lift Control	1	39-42	
9N-533	.12	Ring - Hydraulic Lift Piston	3	39-42	
9N-535	2.15	Rocker - Hydraulic Lift	1	39-42	
352625-S7-8		Pin (Clevis) - Hydraulic Lift	2	39-42	
72036-S		Pin (Cotter)	2	39-42	
9N-539	.10	Spring (Retracting)-Hydraulic Lift Fork .	1	39-42	
9N-540	1.75	Fork - Hydraulic Lift Spring Control	1	39-42	
73956-S		Pin (Clevis) - Plunger to Hydraulic Lift Spring Control Fork	1	39-42	
72010-S		Pin (Cotter) - Plunger to Hydraulic Lift Spring Control Fork Clevis Pin	1	39-42	
9N-541	.40	Plunger - Hydraulic Lift Spring Control .	1	39-42	
9N-543	4.25	Arm - Hydraulic Lift	2	39-42	
9N-544	6.30	Shaft - Hydraulic Lift	1	39-42	
20874-S7-8		Bolt (Hex Head) Hydraulic Lift Shaft	4	39-42	
9N-545	4.85	Arm - Hydraulic Lift Ram	1	39-42	
9N-546	1.75	Yoke - Hydraulic Lift	1	39-42	
9N-547-A	2.65	Spring - Hydraulic Lift (with 9N-510-A) .	1	39-40	Before Tractor #47020 After #47019
9N-547-B	2.65	Spring - (Heavy) Hyd. Lift (9N-510-B) ...	1	39-42	
9N-550	.06	Washer (Lock) - Hydraulic Lift	2	39-42	
9N-551	.10	Washer - Hydraulic Lift	2	39-42	
9N-552	.03	Gasket - Hydraulic Lift	2	39-42	
9N-553	.04	Gasket - Hydraulic Lift	1	39-42	
9N-554	.30	Bearing Assy. - Hydraulic Lift Leveling Gear	1	39-42	
9N-555	9.00	Link - Lower Lift R.H.	1	39-42	
9N-556	9.00	Link - Lower Lift L.H.	1	39-42	
9N-560	.60	Pin - Hydraulic Lift	2	39-42	
9N-562-A	1.30	Plate - Lower Link Support (Oval End) ...	2	39-42	
9N-562-B	1.30	Plate - Lower Link Support (Square End) .	2	39-42	
22267-S7		Bolt (Hex Head) - Lower Link Support to Axle Housing	2	39-42	

FORD TRACTOR PARTS PRICE LIST

Part.No.	Price	Part Name	Unit	Year	Remarks
HYDRAULIC LIFT (CONT'D)					
72017-S		Pin (Cotter) - Lower Link Support to Rear Axle Housing	2	39-42	
9N-563	\$.60	Shaft - Lower Link	2	39-42	
33860-S7		Nut (Castle) - Lower Link Shaft	4	39-42	
72026-S		Pin (Cotter) - Lower Link Shaft	4	39-42	
351505-S7-8		Washer - (Flat) - Lower Link Shaft	4	39-42	
9N-564	3.20	Leveling Rod - Hydraulic Lift L. H.	1	39-42	
9N-565	3.00	Leveling Box - Hydraulic Lift	1	39-42	
74127-S		Plug (Expansion) - Hydraulic Lift			
		Leveling Box Assy.	1	39-42	
353043-A1- S7-8		Fitting (Lubrication) - Hydraulic Lift Leveling Box Assy.	1	39-42	
9N-566	2.40	Knuckle - Hydraulic Lift	2	39-42	
9N-567	.30	Oil Tube - Differential Housing	1	39-42	
9N-568	1.30	Gear - Leveling Lever	1	39-42	
9N-569	18.70	Leveling Box Assy. - Hydraulic Lift	1	39-42	
9N-574	.30	Lynch Pin	4	39-42	
9N-575	.05	Ring - Chain	2	39-42	
9N-576	5.20	Link Assy. - Upper	1	39-42	
20878-S7-8		Bolt (Hex Head) - Upper Link Assy.	2	39-42	
351428-S7-8		Washer (Plain) - Upper Link Assy.	2	39-42	
33792-S7 8-18		Nut (Hex) - Hydraulic Lift Upper Link Bolt	2	39-42	
9N-577	2.25	Link (Half Upper)	2	39-42	
9N-579	3.50	Shaft - Leveling Gear - R.H.	1	39-42	
9N-582	.40	Clevis - Lower Link, Anchor Chain	4	39-42	
9N-583-A	.15	Clip and Chain Assy. (Lower Link)	2	39-42	
9N-583-B	.15	Clip and Chain Assy. (Lower Link) (2 in line Holes)	2	39-42	
9N-585	1.80	Fork - Lift Rod R. H.	1	39-42	
353043-A2- S7-8		Fitting (Lubrication) - Hydraulic Lift Leveling Box Assy.	1	39-42	
9N-587-B	.60	Bolt (Eye) Check Chain	2	39-42	
33792-S7-8-18		Nut (Check) - For Check Chain Eye Bolt ..	2	39-42	
351040-S7-8		Nut (Eye Bolt) - Check Chain	2	39-42	
60453-S		Rivet-Lynch Pin Clip to lower link	4	39-42	
9N-588	.50	Chain and Anchor Assy. Upper Link, Rear .	1	39-42	
9N-590	.10	Chain and Anchor Assy. Upper Link, Front, R.	1	39-42	
9N-594	1.00	Lever (Leveling) - Hydraulic Lift	1	39-42	
351963-S		Rivet (Special Oval C'Sunk Head) - Leveling Lever to Leveling Lever Gear	1	39-42	
9N-595	.30	Pin (Leveling) - Hydraulic Lift Fork	4	39-42	
72035-S		Pin (Cotter) - Leveling Pin	4	39-42	
9N-596	.25	Anchor - Lower Link Check Chain R.H.	1	39-42	
9N-597	.25	Anchor - Lower Link Check Chain L.H.	1	39-42	
21442-S7		Bolt (Hex Head) - Lower Link Check Chain Support to Power Take Off	4	39-42	
9N-598	1.15	Chain Assy. (Lower Link Anchor)	2	39-42	

FORD TRACTOR PARTS PRICE LIST



Part No.	Price	Part Name	Unit	Year	Remarks
HYDRAULIC LIFT (CONT'D)					
73918-S7		Pin (Clevis) - Lower Link Anchor Chain ..	4	39-42	
72010-S		Pin (Cotter) - Lower Link Anchor Chain ..	4	39-42	
9N-599	\$ 8.50	Quadrant and Lever Assy. - Hydraulic Lift.	1	39-42	

HYDRAULIC PUMP

9N-600	54.00	Hydraulic Pump	1	39-42	
9N-604	16.00	Base Assy.-Hydraulic Pump	1	39-42	
355693-S7-8		Bolt (Hex Head) - Hydraulic Pump Base to Center Housing	9	39-42	
351428-S7-8		Washer (Special Plain) - Hydraulic Pump Base	9	39-42	
355650-S		Bolt (Hex Head) 1/2-20-50 Spl.	1	39-42	
9N-609	.30	Clamp - Hydraulic Pump	1	39-42	
9N-611	.30	Gasket - Hydraulic Pump (Bottom)	1	39-42	
9N-613	.15	Gasket - Hydraulic Pump	2	39-42	
9N-615	2.20	Piston - Hydraulic Pump	2	39-42	
9N-617	1.60	Cam Block - Hydraulic Pump	2	39-42	
9N-618	2.80	Cam - Hydraulic Pump	1	39-42	
9N-621	7.50	Valve Chamber Assy. L. H. Hydraulic Pump.	1	39-42	
9N-622	7.50	Valve Chamber Assy. R. H. Hydraulic Pump.	1	39-42	
9N-625	1.75	Bushing (Hydraulic Control Valve)	1	39-42	
9N-626	.05	Guide - Hydraulic Pump Valve	4	39-42	
9N-628	.25	Valve, Outlet	4	39-42	
9N-629	.25	Valve, Inlet	4	39-42	
20881-S7-8		Bolt (Hex Head) - Hydraulic Pump Valve .. Chamber to Pump Body	8	39-42	
21442-S7		Bolt (Hex Head)- Hydraulic Pump Valve Chamber Cap	2	39-42	
9N-636	.20	Plug - Hydraulic Pump	4	39-42	
9N-638	1.20	Safety Valve Assy. - Hydraulic Pump	1	39-42	
9N-640	1.40	Control Valve Assy. - Hydraulic Pump	1	39-42	
9N-646	.02	Spring Outlet Valve	4	39-42	
9N-647	.01	Spring Inlet Valve	4	39-42	
9N-649	1.35	Bushing - Hydraulic Pump	1	39-42	

POWER TAKE-OFF ASSEMBLY AND PULLEY ATTACHMENT

(See Illustration on Page 10)

9N-700-B	17.00	Power Take-Off Shaft Assy.	1	39-42	When Replacing Shaft in Tractors Before #7452 Also Use 9N-728-B and 73984-S.
9N-710	8.50	Shaft and Sleeve Assy. - Power Take-Off ..	1	39-42	
73984-S		Pin-Power take-off shaft- After Tr. #7452 ..	1	39-42	
72003-S7-8		Pin (Cotter) (For Clevis Pin)	1		
9N-712	2.60	Bearing Assy. (Rear) - Power Take-Off ...	1	39-42	
9N-713	15.00	Gear Assy. - Power take-off	1	39-42	
9N-714	.07	Washer - Power Take-Off	1	39-42	
9N-715	2.50	Bearing Assy. - Power Take-Off	1	39-42	
9N-716	1.10	Hub - Power Take-Off Clutch	1	39-42	
351406-S7		Washer (Special) - Power Take-Off	1	39-42	
20389-S		Bolt (Hex Head) - Power Take-Off Clutch Hub	1	39-42	
34807-S7-8		Washer (Lock) - Power Take-Off Clutch Hub Bolt	1	39-42	
9N-717	3.00	Sleeve - Power Take-Off Clutch	1	39-42	
9N-718	3.25	Support - Power Take-Off Shaft Bearing ..	1	39-42	
355545-S		Bolt (Hex Head) - Power Take-Off Shaft Bearing Support	4	39-42	
34807-S7-8		Washer (Lock) - Power Take-Off Shaft Bearing Support	4	39-42	

FORD TRACTOR PARTS PRICE LIST

Part No.	Price	Part Name	Unit	Year	Remarks
----------	-------	-----------	------	------	---------

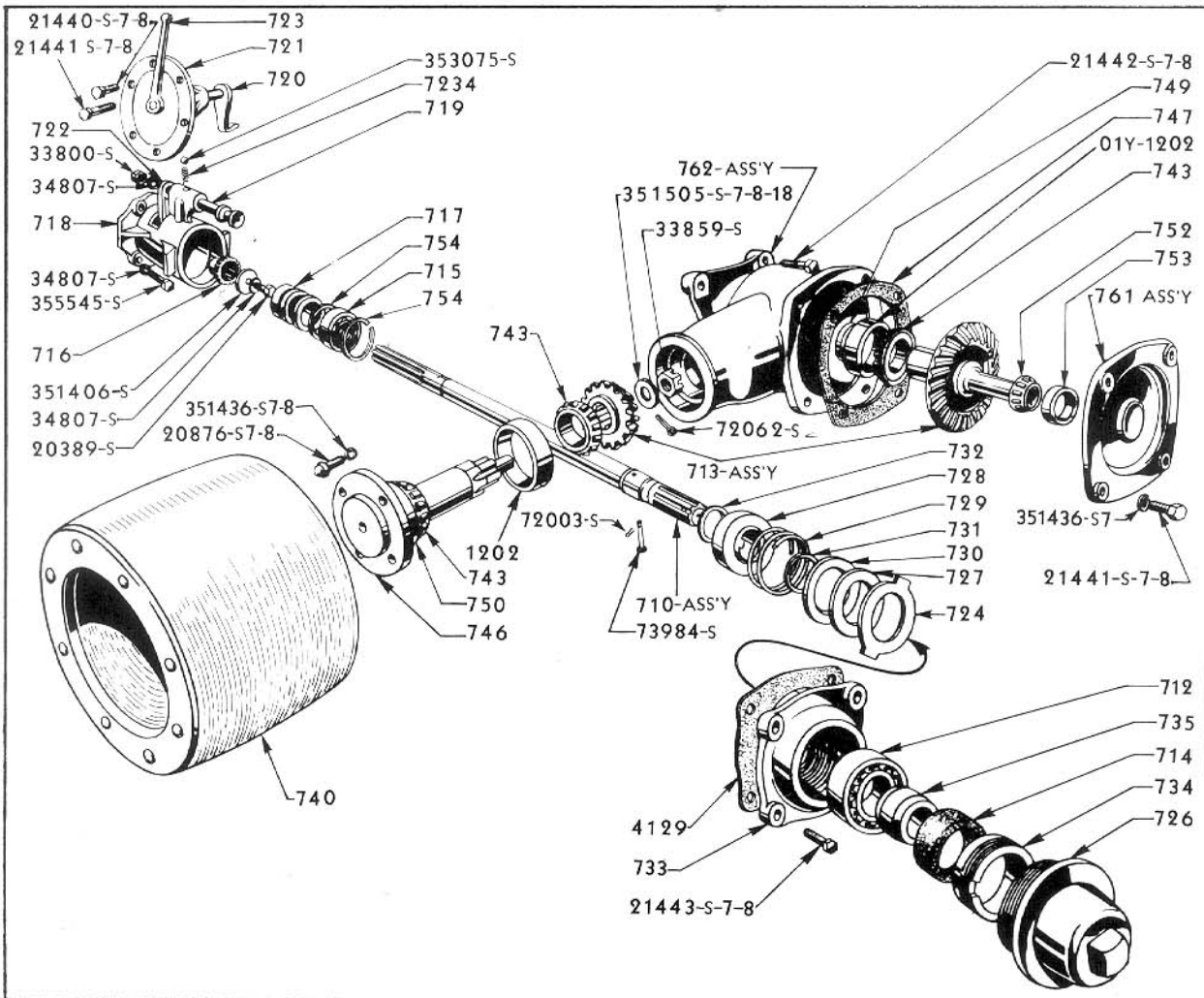

POWER TAKE-OFF ASSEMBLY AND PULLEY ATTACHMENT (CONT'D)

9N-719	\$ 1.65	Rail - Power Take-Off Shift	1	39-42	
79-7234		Spring - Power Take-Off Shifter	1	39-42	
353075-S		Ball (Steel) - Power Take-Off Clutch Shaft	1	39-42	
33800-S7-8		Nut (Hex) - Power Take-Off Shift Rail ...	1	39-42	
34807-S7-8		Washer (Lock) - Power Take-Off Shift Rail	1	39-42	
9N-720	.75	Fork - Power Take-Off Shifter	1	39-42	
9N-721	1.90	Plate - Power Take-Off Shifter	1	39-42	
21440-S7		Bolt (Hex Head) - Shifter Plate Power Take-Off	4	39-42	
21441-S7		Bolt (Hex Head) - Side Cover and Brake Sector	2	39-42	
9N-722	.35	Stop - Power Take-Off Shifter	1	39-42	
9N-723	.45	Lever - Power Take-Off Shifter	1	39-42	
60518-S		Rivet - Power Take-Off Shift Lever	1	39-42	
9N-724	.75	Washer - Power Take-Off	1	39-42	

FORD TRACTOR PARTS PRICE LIST



Part No.	Price	Part Name	Unit	Year	Remarks
POWER TAKE-OFF ASSEMBLY AND PULLEY ATTACHMENT (CONT'D)					
9N-725-A		Shaft - Power Take-Off Before Tractor No. 7453	1	39-42	Replaced by 9N-710, 9N-728-B and 73984-S
9N-726	\$.85	Cap - Power Take-Off	1	39-42	
9N-727	.20	Seal - Power Take-Off	1	39-42	
9N-728-A	.35	Case - Power Take-Off Seal Before Tractor No. 7453	1	39-42	
9N-728-B	.35	Case - Power Take-Off After Tractor No. 7452	1	39-42	
9N-729	.12	Spring - Power Take-Off	1	39-42	
9N-730	.07	Guide - Power Take-Off Spring	1	39-42	
9N-731	.06	Ring - Power Take-Off Clamp	1	39-42	
9N-732	.03	Ring (Snap) - Power Take-Off	1	39-42	
9N-733	1.70	Cover - Power Take-Off	1	39-42	
21443-S7		Bolt (Hex Head) - Power Take-Off Housing Cover	4	39-42	
9N-734	.90	Retainer - Power Take-Off	1	39-42	
9N-735	.30	Sleeve - Power Take-Off	1	39-42	
9N-740-A	5.30	Pulley (9") - Power Take-Off	1		
9N-740-B	5.30	Pulley (8") - Power Take-Off (Optional)		39-42	
20876-S7-8		Bolt (Hex Head) - Pulley To Power Take-Off Drive Shaft	4	39-42	
351436-S7-8		Washer (Lock) - Power Take-Off Pulley	4	39-42	
9N-743	1.20	Cone - Power Take-Off Gear Bearing	3	39-42	
01Y-1202	.45	Cup - Power Take-Off Gear Bearing	3	39-42	
351505-S7-8-18		Washer (Flat) - Power Take-Off Pulley Driver Gear	1	39-42	
33859-S		Nut (Castle) - Power Take-Off Driving Gear	1	39-42	
72062-S		Pin (Cotter) - Power Take-Off Driving Gear	1	39-42	
9N-746	6.75	Shaft - Power Take-Off Pulley	1	39-42	
9N-747	.05	Gasket - Power Take-Off Cover	1	39-42	
9N-749	.80	Seal - Power Take-Off Gear Bearing Oil ..	1	39-42	
9N-750	.90	Seal - Power Take-Off Pulley Bearing Oil.	1	39-42	
9N-752	.75	Cone and Roller Assy. - Power Take-Off Gear Pilot Bearing	1	39-42	
9N-753	.35	Cup - Power Take-Off Gear Pilot Bearing .	1	39-42	
9N-754	.05	Ring (Snap) - Power Take-Off Bearing	2	39-42	
9N-761	3.00	Cover and Cup Assy. - Power Take-Off	1	39-42	
21441-S7		Bolt (Hex Head) - Power Take-Off Housing Cover	4	39-42	
9N-762	13.60	Housing and Cups Assy. - Power Take-Off .	1	39-42	
353064-S		Plug (Pipe) - Drain	1	39-42	

WHEELS AND WHEEL HUBS

9N-1012	.10	Nut - Wheel Bolt (Front)	10	39-42
9N-1015	5.00	Wheel Assy. - Front	2	39-42
9N-1104-B	8.65	Hub Assy. - Front Wheel	2	39-42
78-1107	.06	Bolt - Wheel Hub (Front Wheels Only) Press Fit	10	39-42
9N-1108-C	12.00	Rim and Band Assy. - Rear 8 x 32	2	39-42
9N-1108-D	12.00	Rim and Band Assy. - Rear 10 x 28	2	39-42
350719-S7		Bolt (Round Head) - Rim to Disc	12	39-42
33806-S7-8-18		Nut (Hex) - Clamp to Disc Wheel	12	39-42
351505-S7-8		Washer (Flat) - Rear Disc Wheel to Hub ..	12	39-42



FORD TRACTOR PARTS PRICE LIST

Part No.	Price	Part Name	Unit	Year	Remarks
WHEELS AND WHEEL HUBS (CONT'D)					
9N-1117	\$.15	Bolt - Rear Wheel Disc to Brake Drum	12	39-42	
9N-1122-D	9.50	Disc - Wheel Rear 32 x 8.00	2	39-42	
9N-1122-E	8.50	Disc - Rear Wheel 10' x 28	2	39-42	
33806-S7-8-18		Nut (Hex) - Rear Axle to Rear Wheel	12	39-42	
351505-S7-8		Washer (Flat) - Rear Axle to Rear Wheel Bolt	12	39-42	
9N-1126-B	5.50	Brake Drum	2	39-42	
9N-1139	.55	Cap - Front Hub	2	39-42	} Required when installing Dust Seal in 9N-1104-A Hub
9N-1190-B	.70	Cap - Front Hub Dust	2	39-42	
9N-1191	.10	Spacer - Front Hub Dust	2	39-42	
9N-1195	.04	Washer - Front Hub Bearing Retainer	2	39-42	
B-1201	1.10	Cone and Roller Assy. - Front Wheel Inner Bearing	2	39-42	
B-1202	.45	Cup - Front Wheel Inner Bearing	2	39-42	
B-1216	.70	Cone and Roller Assy. - Front Wheel Outer Bearing	2	39-42	
B-1217	.30	Cup - Front Wheel Outer Bearing	2	39-42	

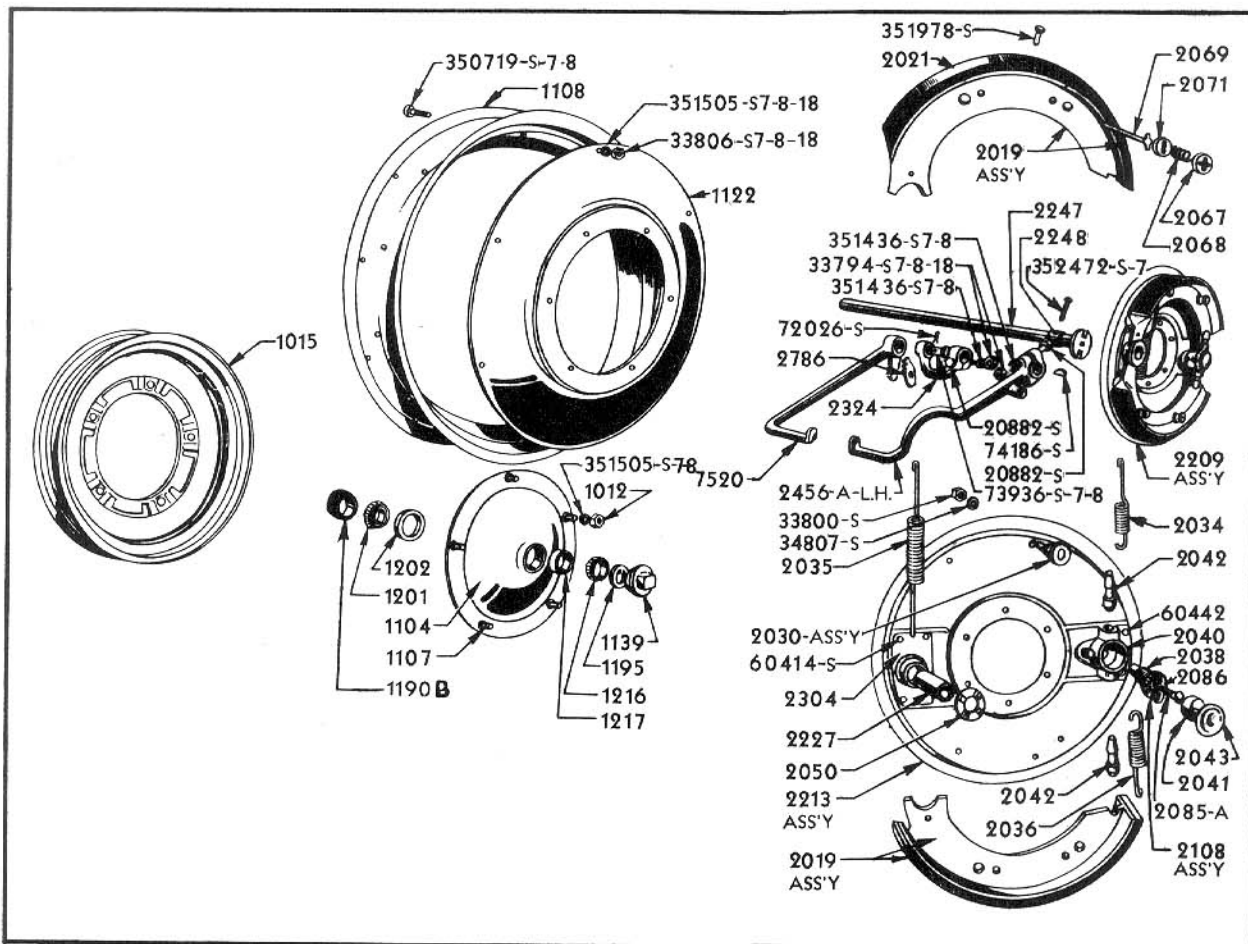

FORD TRACTOR PARTS PRICE LIST



Part No.	Price	Part Name	Unit	Year	Remarks
BRAKES					
9N-2019	\$ 3.75	Brake Shoe and Lining Assy.	4	39-42	
92Y-2021-B	1.00	Lining - Brake Shoe	4	39-42	
351978-S		Rivet - Brake Lining to Brake Shoe	60	39-42	
9N-2030	.30	Equalizer Assy. - Brake	2	39-42	
33800-S7-8		Nut (Hex) - Brake Eccentric	2	39-42	
34807-S7-8		Washer (Lock) - Brake Equalizer	2	39-42	
9N-2034	.06	Spring (Return) - Brake Shoe	2	39-42	
9N-2035	.12	Spring (Return) - Brake Shoe - Long	2	39-42	
9N-2036	.06	Spring (Return) - Brake Shoe Adjusting Side Lower	2	39-42	
81T-2038	.25	Stem (Adjusting) - Brake	2	39-42	
9N-2040	.85	Bracket (Adjusting) - Brake	2	39-42	
60442-S		Rivet (Round Head) - Brake Adjusting Bracket to Brake Plate	6	39-42	
9N-2041	.40	Wedge - Adjusting	2	39-42	
81T-2042	.25	Link - Brake Shoe	4	39-42	
9N-2043	.02	Cap - Brake Adjusting Bracket	2	39-42	
9N-2050	1.30	Wedge - (Operating) - Brake	2	39-42	
78-2067-C	.01	Cap - Brake Shoe Hold Down Spring	4	39-42	
9N-2068	.02	Spring (Hold Down) - Brake Shoe	4	39-42	
9N-2069	.01	Pin (Hold Down) - Brake Shoe	2	39-42	
78-2071	.01	Nut - Brake Shoe Hold Down Spring Centralizer	4	39-42	
78-2085-A	.02	Pin - Brake Adjusting Stem Spring	2	39-42	
78-2086	.02	Spring (index) Brake Adjusting Stem	2	39-42	
81T-2108	.25	Spring Assy. - Adjusting Stem	2	39-42	
9N-2209-B	14.50	Brake Assy. - R.H. - With Seal	1	39-42	
9N-2210-B	14.50	Brake Assy. - L.H. - With Seal	1	39-42	
9N-2213-B	5.65	Brake Carrier Plate and Brackets - Assy. Right or Left - With Seal	1	39-42	
9N-2217	.55	Ring - Felt, Brake Dust Seal	2	39-42	
9N-2227	.20	Bushing - Graphite	2	39-42	
9N-2247	4.25	Shaft - Brake	2	39-42	
9N-2248	.30	Collar - Brake Shaft	2	39-42	
352472-S7-8		Pin - Brake Shaft Collar	2	39-42	
9N-2252	.50	Ring - Brake Dust Seal	2	39-42	
9N-2279	.05	Clip - Wiring	1	39-42	
9N-2304	.85	Bracket - Brake Camshaft	2	39-42	
60414-S		Rivet (Round Head) - Brake Camshaft Bracket	8	39-42	
9N-2324	1.85	Arm - Brake Pawl	1	39-42	
20882-S7-8		Bolt (Hex Head) - Brake Pawl Arm	1	39-42	
33794-S7-8		Nut (Hex) - Brake Pawl Arm	1	39-42	
351436-S7-8		Washer (Lock) - Brake Pawl Arm	1	39-42	
9N-2455-A	3.75	Pedal - Brake R.H.	1	39-42	
9N-2456-A	3.75	Pedal - Brake L.H.	1	39-42	
74186-S		Key (Woodruff) - Brake Pedal and Pawl ...	2	39-42	
20882-S7-8		Bolt (Hex Head) - Brake Pedal	4	39-42	
33794-S7-8		Nut (Hex) - Brake Pedal Bolt	4	39-42	
351436-S7-8		Washer (Lock) - Brake Pedal	4	39-42	
78-2477	.10	Bushing - Brake Cross Shaft	2	39-42	
9N-2786	.40	Pawl - Brake	2	39-42	
73936-S7-8		Pin (Clevis) - Brake Pawl L.H.	1	39-42	
74079-S7-8		Pin (Clevis) - Brake Pawl R.H.	1	39-42	
72026-S		Pin (Cotter) - Brake Pawl	2	39-42	
9N-2796	.60	Sector - Brake	2	39-42	

FORD TRACTOR PARTS PRICE LIST

Part No.	Price	Part Name	Unit	Year	Remarks
FRONT AXLE					
9N-3006	\$15.00	Axle - Front R.H. Half With Bushings	1	39-42	
9N-3007	15.00	Axle - Front L.H. Half With Bushings	1	39-42	
353027-A2-S7-8		Fitting - Lubrication	2	39-42	
9N-3010	15.00	Center - Front Axle	1	39-42	
9N-3029	9.25	Support Assy. - Front Axle	1	39-42	
9N-3039	.20	Bushing Assy. - Front Axle	1	39-42	
21182-S7-8		Bolt (Hex Head) - Front Axle Center to Half	4	39-42	
33806-S7-8-18		Nut (Hex) - Front Axle Center to Front Axle Half Bolt	4	39-42	
351505-S-7-8 8-18		Washer (Flat) - Front Axle Center to Front Axle Half Bolt	4	39-42	
20880-S7-8		Bolt (Hex Head) - Front Axle Support to Oil Pan	6	39-42	
33792-S7-8-18		Nut (Hex) Front Axle Support	6	39-42	
9N-3105	11.70	Spindle Assy. - Front Axle	2	39-42	
351129-S		Nut (Castle) - Front Axle Spindle Assy. .	2	39-42	
72054-S		Pin (Cotter) - Spindle Nut	2	39-42	
9N-3109	.25	Bushing - Spindle	4	39-42	
9N-3122	.15	Pin - Spindle Bolt Locking	2	39-42	
33792-S7-8-18		Nut (Hex) - Front Axle Spindle Pin	2	39-42	
351436-S7-8		Washer (Lock) - Front Axle Arm	2	39-42	
9N-3123	.50	Bearing - Front Axle Spindle	2	39-42	
9N-3126-A	1.50	Pin - Front Axle	1	39-42	
350635-S7-8		Bolt (Hex Head) - Front Axle Pin	1	39-42	
33790-S7-8		Nut Check (Hex Head) - Axle to Axle Support	1	39-42	

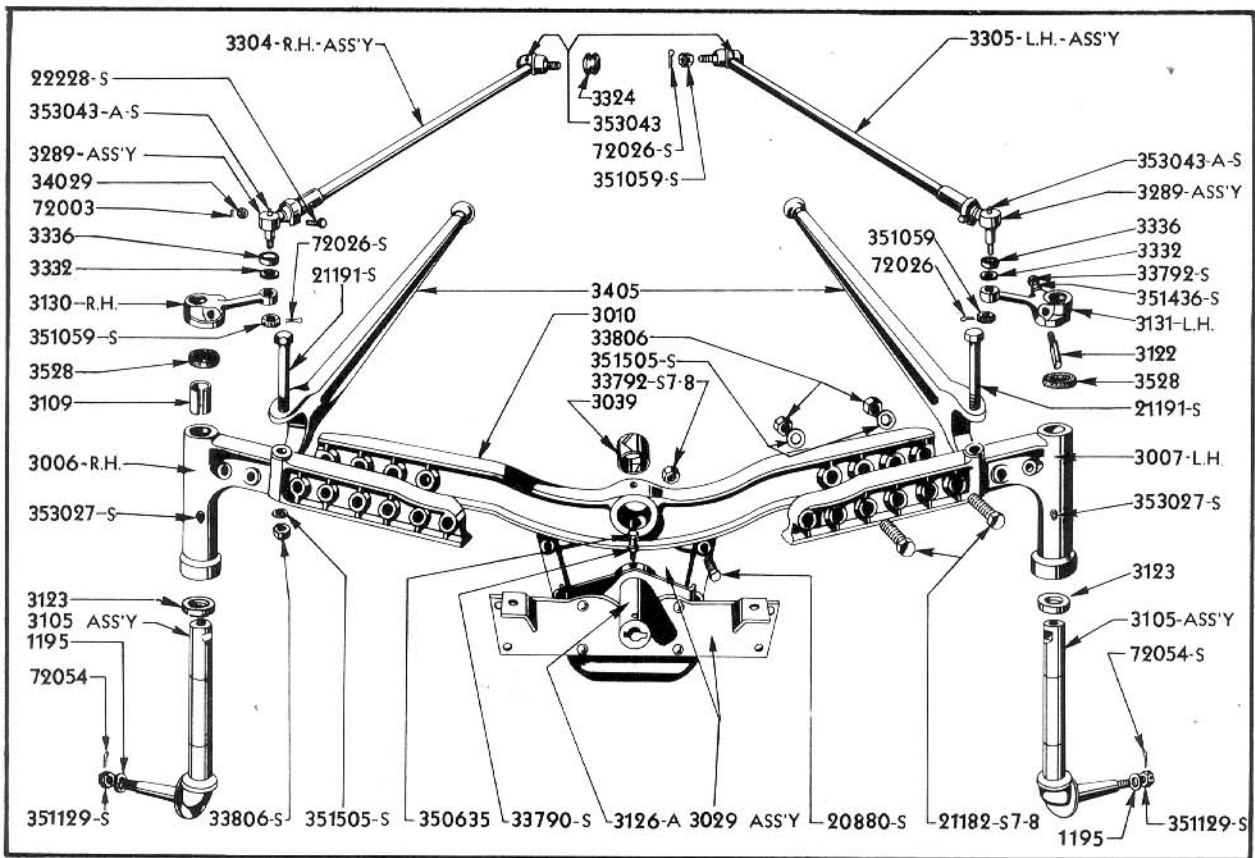

FORD TRACTOR PARTS PRICE LIST

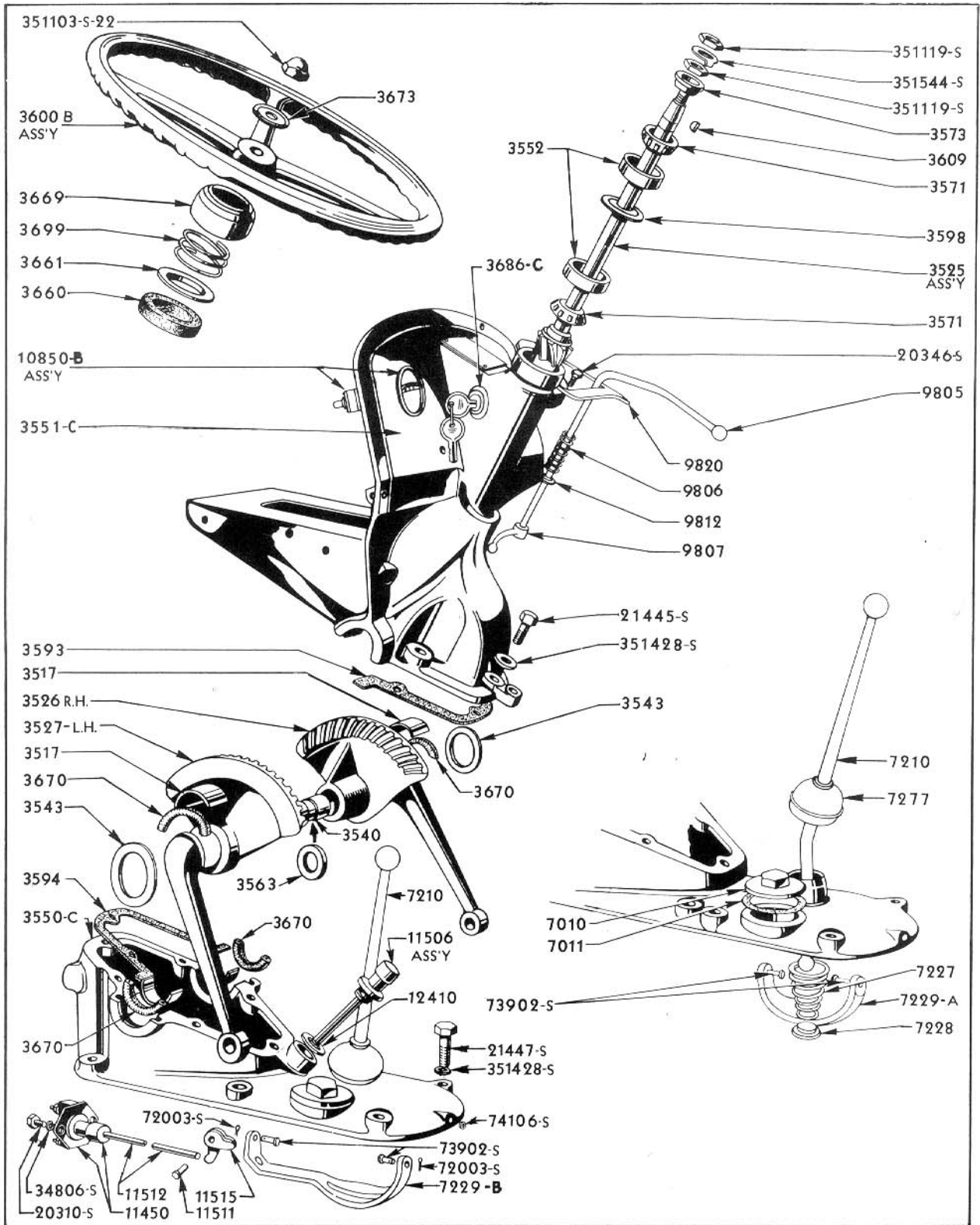

FORD TRACTOR PARTS PRICE LIST

Part No.	Price	Part Name	Unit	Year	Remarks
FRONT AXLE (CONT'D)					
9N-3130	\$ 4.25	Arm - Spindle R.H.	1	39-42	
9N-3131	4.25	Arm - Spindle L.H.	1	39-42	
11A-3289-B	1.00	Spindle Ball Joint Assy.	2	39-42	
351059-S7-8		Nut (Castle) - Spindle Ball Joint Assy. .	4	39-42	
72026-S		Pin (Cotter) - Drag Link	4	39-42	
9N-3304	4.00	Link Assy. - Steering Drag R.H.	1	39-42	
9N-3305	4.00	Link Assy. - Steering Drag L.H.	1	39-42	
353043-A-S7-8		Fitting (Lubrication) - Steering Drag Link	4	39-42	
9N-3324	.30	Cover Assy. - Dust	2	39-42	
78-3332	.02	Cover - Spindle Connecting Rod Ball Stud Dust	2	39-42	
78-3336	.01	Retainer - Steering Drag Link and Tie Rod Grease	2	39-42	
22228-S7		Bolt - Steering Drag Link Clamp	2	39-42	
34029-S7-8		Nut (Hex) - Steering Drag Link Clamp	2	39-42	
72003-S7-8		Pin (Cotter) - Steering Drag Link Clamp .	2	39-42	
9N-3405	7.00	Rod - Front Radius	2	39-42	
21191-S7-8		Bolt (Hex Head) - Front Axle to Radius Rod	2	39-42	
33806-S7-8-18		Nut (Hex) - Front Axle to Radius Rod Bolt	2	39-42	
351505-S7-8		Washer (Flat) - Front Axle to Radius Rod Bolt	2	39-42	
9N-3440	.80	Cap - Radius Rod Ball	4	39-42	
88523-S		Stud (Screw) - Radius Rod Ball Cap	4	39-42	
33792-S7-8-18		Nut (Hex) - Radius Rod Ball Spacer Cap ..	4	39-42	
351436-S7-8		Washer (Lock) - Radius Rod Ball Cap Stud.	4	39-42	
9N-3442	1.00	Spacer - Radius Rod Ball	2	39-42	
88398-S		Stud (Screw) - Radius Rod Ball Spacer ...	2	39-42	
33792-S7-8-18		Nut (Hex) - Radius Rod Spacer	2	39-42	
351436-S7-8		Washer (Lock) - Radius Rod Ball Spacer ..	2	39-42	

STEERING GEAR

9N-3501-A	*54.00	Steering Gear Assy. Less Instruments and Throttle Control	1	39-42	
9N-3501-B	*56.00	Steering Gear Assy. Less Instruments and Throttle Control	1	39-42	
9N-3501-C	*56.00	Steering Gear Assy. Less Instruments and Throttle Control	1	41	
9N-3512	1.10	Instrument Panel Assembly	1	41-42	
9N-3517	.35	Bearing - Steering Sector	4	39-42	
9N-3525	8.35	Shaft and Pinion - Steering Gear	1	39-42	
351119-S7		Nut (Hex) - Steering Shaft	2	39-42	
351544-S		Washer (Lock) - Steering Shaft	1	39-42	
9N-3526	12.50	Sector - Steering Gear R.H.	1	39-42	
9N-3527	12.50	Sector - Steering Gear L.H.	1	39-42	
9N-3528	.02	Seal - Steering Arm Dust	1	39-42	
9N-3540	.80	Shaft - Steering Sector	1	39-42	
9N-3543-A	.40	Washer - Steering Sector Outer Thrust Thin	2	39-42	
9N-3543-B	.40	Washer - Steering Sector Outer Thrust Thick	2	39-42	
9N-3550-A	*12.50	Housing - Steering Gear Lower	1	39-42	

* Not subject to regular discount.

FORD TRACTOR PARTS PRICE LIST



Part No.	Price	Part Name	Unit	Year	Remarks
STEERING GEAR (CONT'D)					
9N-3550-C	*\$15.50	Housing - Steering Gear Lower		40-42	After Trac. #47507
74106-S 21447-S7-8		Plug (Expansion) - Steering Gear Housing. Bolt (Hex Head) - Lower Steering Housing to Transmission Housing	1 6	39-42 39-42	
9N-3551-A	*19.00	Housing - Steering Gear Upper	1	39-42	After 47507
9N-3551-C	*19.00	Housing - Steering Gear Upper	1	40-42	
9N-3551-D	*13.60	Housing - Steering Gear Upper	1		
21445-S7		Bolt (Hex Head) - Upper to Lower Steering Gear Housing	6	39-42	
B-3552	.25	Cup - Steering Gear Worm Bearing Lower ..	2	39-42	
9N-3563-A	.35	Washer - Steering Sector Inner Thrust Thick	1	39-42	
9N-3563-B	.35	Washer - Steering Sector Inner Thrust Thin	1	39-42	
68-3571-A	.25	Roller Assy. - Steering Gear	2	39-42	
9N-3573	.50	Cone - Steering Gear Bearing	2	39-42	
9N-3593-B	.01	Gasket - Steering Gear Housing - Rear ...	1	39-42	
9N-3594	.01	Gasket - Steering Gear Housing - Front ..	1	39-42	
9N-3598	.04	Retainer - Steering Column Oil	1	39-42	
9N-3600-B	4.00	Wheel Assy. - Steering	1	39-42	
351103-S-22		Nut - Steering Wheel	1	39-42	
B-3609	.02	Key - Woodruff	1	39-42	
9N-3627	.80	Cap - Steering Wheel Center	1	39-42	
9N-3660	.06	Seal - Steering Column Dust	1	39-42	
9N-3661	.10	Retainer - Steering Column Seal	1	39-42	
9N-3669	.15	Cap - Steering Column	1	39-42	
9N-3670	.06	Packing - Steering Sector	4	39-42	
9N-3673	.65	Washer - Steering Wheel	1	39-42	
9N-3685-A	.50pr	Key - Ignition Lock #1050 to 1300	2	39-42	Used All Trs. On and After 76000.
9N-3685-B	.50pr	Key - Ignition Lock (Universal) #1053 ...	2	41-42	
9N-3686-C	.85	Lock Cylinder Assy. - Ignition	1	39-42	
26456-S7		Screw (Round Head) - Ignition Lock Cylinder Assy.	2	39-42	
351118-S7-8		Nut (Hex) - Ignition Lock Cylinder Assy..	1	39-42	
9N-3699	.15	Spring - Steering Column Dust Seal	1	39-42	
9N-3701	.10	Lens - Ignition Indicator Lamp	1	39-42	

REAR AXLE

9N-4000	*250.00	Rear Axle Assy.	1	39-42	
9N-4005	*92.00	Axle Assy. - Rear - Less Hydraulic Mech- anism, Pump, Axle Shafts, and Brakes	1	39-42	
9N-4012-B	*17.30	Housing - Rear Axle R.H.	1	39-42	
74121-S		Plug (Expansion) - Rear Axle Housing	1	39-42	
353064-S		Plug Drain - Rear Axle Housing	1	39-42	
9N-4013-B	*17.30	Housing - Rear Axle Shaft L.H.	1	39-42	
357724-S7		Stud - Rear Axle Housing to Center Housing	21	39-42	

*Not subject to regular discount



FORD TRACTOR PARTS PRICE LIST

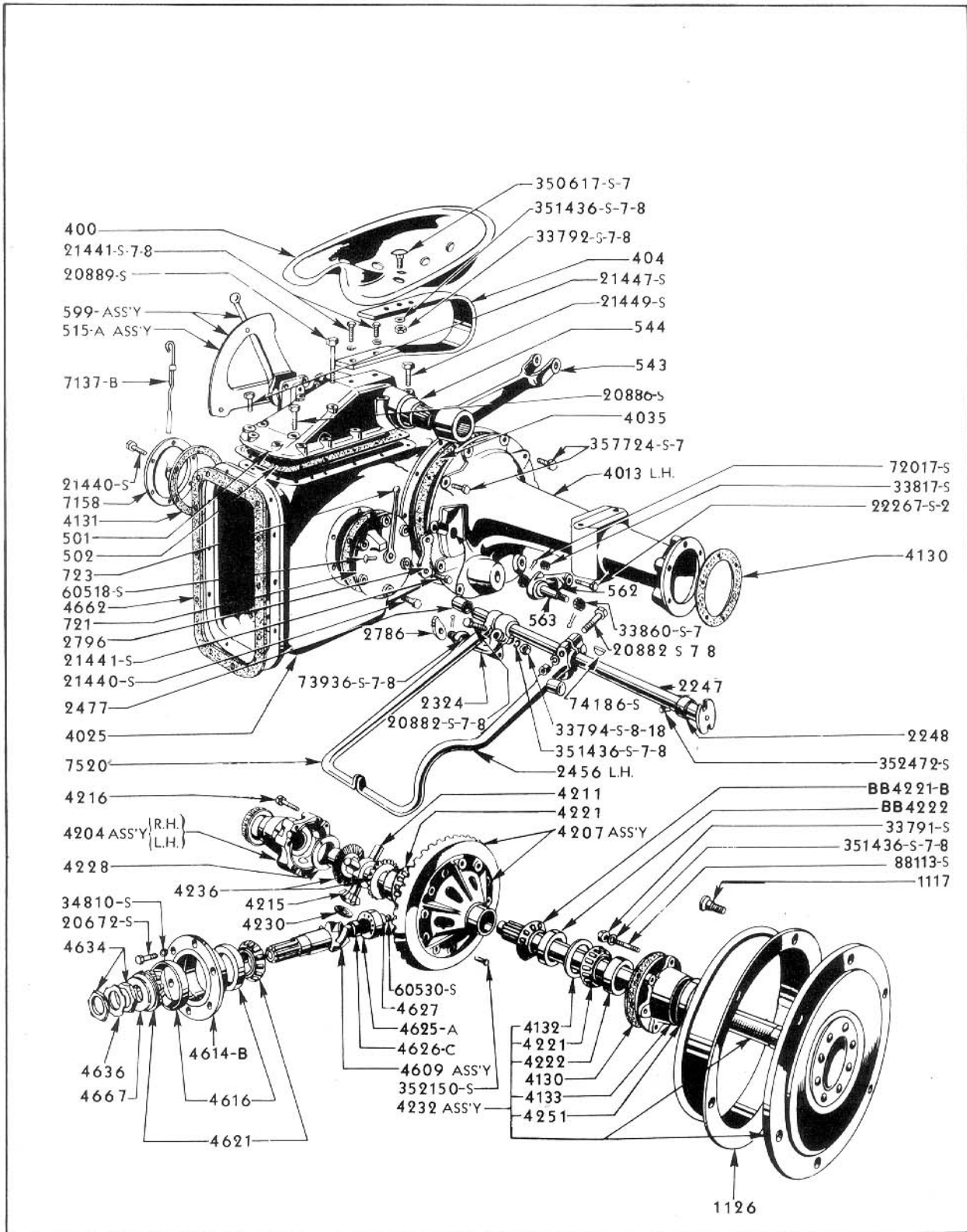

FORD TRACTOR PARTS PRICE LIST



Part No.	Price	Part Name	Unit	Year	Remarks
REAR AXLE (CONT'D)					
9N-4025	\$56.00	Housing - Center	1	39-42	
353064-S		Pipe Plug - Drain	1	39-42	
9N-4035	.20	Gasket - Rear Axle Differential Housing .	2	39-42	
9N-4129	.04	Gasket - Power Take-Off Cover	1	39-42	
9N-4130	.06	Gasket - Axle Housing (Outer)	2	39-42	
9N-4131	.06	Gasket - Differential Housing Side	2	39-42	
9N-4132	.50	Collar - Axle Shaft Bearing	2	39-42	
9N-4133	3.20	Retainer - Axle Shaft Bearing	2	39-42	
88113-S7		Stud (Screw) - Rear Axle Housing to Bearing Retainer	12	39-42	
33791-S7		Nut (Regular) - Rear Axle Shaft Bearing Retainer to Axle Shaft Housing	12	39-42	
351436-S7-8		Washer (Lock) - Axle Bearing Retainer to Axle Shaft Housing	12	39-42	
9N-4150	.35	Trough Assy. - Differential Bearing Oil .	1	39-42	
9N-4195	2.50	Spacer - Driving Gear Thrust Block	1	39-42	
20388-S2		Bolt (Hex Head) - Driving Gear Thrust Block Spacer to Rear Axle Center Housing	2	39-42	
34807-S7-8		Washer (Lock) - Thrust Block to Axle Housing Bolt	2	39-42	
9N-4201	*44.00	Differential Assy. - Rear Axle	1	39-42	
9N-4203	*35.00	Gear, Pinion, and Case - Differential ...	1	39-42	
9N-4204	13.00	Case Assy. - Differential Gear	1	39-42	
9N-4207	39.00	Gear & Case Assy. (Service Only)	1	39-42	
79-4210	*18.75	Gear Only, Driving	1	39-42	
352150-S		Rivet (Round Head) - Driving Gear to Differential Gear Case	12	39-42	
9N-4211	3.20	Spider - Differential	1	39-42	
91T-4215	.90	Gear - Differential Pinion	4	39-42	
BB-4216-C	.20	Screw - Differential Gear Case	8	39-42	
9N-4221	2.80	Cone and Roller Assy. - Rear Wheel	2	39-42	
BB-4221-B	2.65	Cone and Roller Assy. - Axle Shaft Inner Bearing	2	39-42	
9N-4222	1.50	Cup - Rear Wheel Bearing	2	39-42	
BB-4222	1.45	Cup - Axle Shaft Inner Bearing	2	39-42	
79-4228	.20	Washer - Differential Gear Thrust	2	39-42	
9N-4229-A	.05	Shim - Rear Axle Bearing .003 Thick	2	39-42	
9N-4229-B	.05	Shim - Rear Axle Bearing .005 Thick	2	39-42	
9N-4229-C	.05	Shim - Rear Axle Bearing .010 Thick	2	39-42	
79-4230	.04	Washer (Thrust) - Differential Pinion ...	4	39-42	
9N-4231	42.00	Axle Shaft and Brake Drum Assy. with Bearing, Retainer and Seal	2	39-42	
9N-4232	37.00	Axle Shaft with Bearing, Retainer, Seal and Studs	2	39-42	
9N-4234-B	31.75	Axle Shaft and Brake Plate Assy.	2	39-42	
60592-S		Rivet - Axle Shaft to Hub Rear	16	39-42	
91T-4236	2.55	Gear - Differential	2	39-42	
9N-4251	.90	Oil Seal - Rear Axle Bearing	2	39-42	
9N-4605	5.30	Drive Shaft Assy.	1	39-42	
79-4609	8.25	Pinion - Gear Assy.	1	39-42	
BB-4614-B	4.70	Sleeve, Pin and Bearing Cups Assy. Driving Pinion Bearing	1	39-42	
20672-S		Bolt (Hex Head)-Pinion Bearing Retainer to Housing	6	39-42	
34810-S		Washer (Lock)-Pinion Bearing Retainer to Rear Axle Housing	6	39-42	
BB-4616-B	1.35	Cup - Driving Pinion Bearing	2	39-42	

* Not subject to regular discount.



FORD TRACTOR PARTS PRICE LIST

Part No.	Price	Part Name	Unit	Year	Remarks
REAR AXLE (CONT'D)					
BB-4621-B	\$ 2.65	Cone and Roller Assy. - Driving Pinion Bearing	2	39-42	
81B-4625-A	1.30	Bearing Assy. - Driving Pinion Pilot	1	39-42	
BB-4626-C	.45	Race, Inner, Driving Pinion Pilot Bearing	1	39-42	
BB-4627	.03	Ring (Lock)-Driving Pinion Pilot Bearing.	1	39-42	
60530-S		Rivet (Round Head) Driving Pinion Bearing Retainer	2	39-42	
B-4634	.20	Nut (Lock)-Driving Pinion Bearing	2	39-42	
B-4636-A	.04	Washer (Lock)-Driving Pinion Bearing	1	39-42	
9N-4662	.20	Gasket - Differential to Transmission Housing	1	39-42	
BB-4667	.15	Washer (Thrust)-Driving Pinion Bearing ..	1	39-42	
BB-4668-B		Sleeve - Service BB-4614-B			

DRAWBAR

(See Illustration on Page 6)

9N-5182	7.75	Drawbar	1	39-42	
9N-5370	.85	Chain and Wedge Assy. - Drawbar	1	39-42	
9N-5372	2.35	Stay Assy. - Drawbar R.H.	1	39-42	
9N-5373	2.00	Stay Assy. - Drawbar L.H.	1	39-42	
9N-5374	.90	Stay - Drawbar Upper	1	39-42	
9N-5375	.90	Stay - Drawbar Lower	1	39-42	
20873-S7-8		Bolt (Hex Head)-Drawbar Stay	4	39-42	
33792-S7-8-18		Nut (Hex)-Drawbar Stay Bolt	4	39-42	
351428-S7-8		Washer (Special Plain)-Drawbar Stay	4	39-42	

MUFFLER ASSEMBLY

9N-5230-A	3.15	Muffler Assy.	1	39-42	
9N-5251	.50	Clamp - Muffler Inlet Pipe	2	39-42	
21477-S7-8		Bolt (Hex Head)-Exhaust Pipe Clamp	2	39-42	
33825-S7-8		Nut (Hex)-Exhaust Pipe Clamp Bolt	2	39-42	
9N-5252	.40	Bracket and Clamp Assy. - Muffler	1	39-42	
20879-S7		Bolt (Hex Head)-Muffler Clamp to Transmission Housing	1	39-42	
33792-S7-8-18		Nut (Hex)-Muffler Clamp to Transmission Housing	1	39-42	
351436-S7-8		Washer (Lock)-Muffler Clamp to Transmission Housing	1	39-42	
20426-S7		Bolt (Hex Head)-Muffler Clamp	1	39-42	
33797-S7-8		Nut (Hex)-Muffler Clamp Bolt	1	39-42	
34806-S7-8		Washer (Lock)-Muffler Clamp Bolt	1	39-42	
9N-5255	.40	Pipe (Outlet) - Muffler	1	39-42	
9N-5260	.20	Bracket - Muffler Outlet Pipe	1	39-42	
88423-S		Stud - Clamp to Rear Axle Housing	1	39-42	
33792-S7-8-18		Nut (Hex)-Clamp to Rear Axle Housing Stud	1	39-42	
23423-S7		Bolt (Hex Head)-Muffler Outlet Pipe Bracket	1	39-42	
34806-S7-8		Washer (Lock) - Muffler Outlet Pipe	1	39-42	
33797-S7-8		Nut (Hex)-Muffler Outlet Pipe Bracket Bolt	1	39-42	
9N-5290	1.50	Shield Assy. - Exhaust Pipe	1	39-42	
9N-5293	.15	Clamp - Exhaust Pipe Shield	1	39-42	
24327-S7		Bolt (Hex Head)-Exhaust Pipe Shield Clamp	2	39-42	
34806-S7-8		Washer (Lock)-Exhaust Pipe Shield Assy. Bolt	2	39-42	

FORD TRACTOR PARTS PRICE LIST

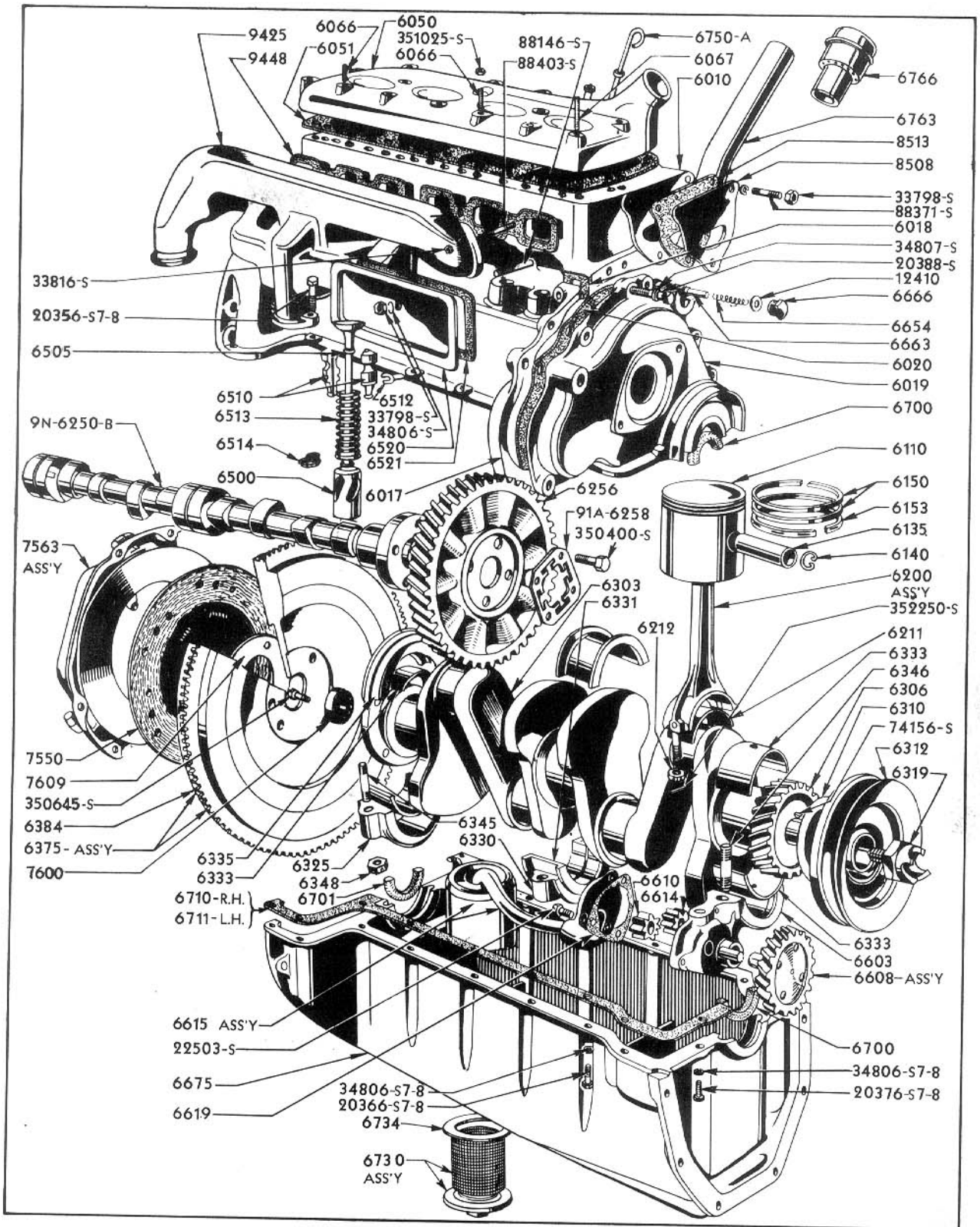



FORD TRACTOR PARTS PRICE LIST

Part No.	Price	Part Name	Unit	Year	Remarks
ENGINE					
9N-6005	*180.00	Engine Assy. (Less Transmission and Clutch) (See Bulletin #111)	1	39-42	
9N-6010	* 53.50	Cylinder Block Assy. with Sleeves and Bearing Caps	1	39-42	
9N-6011	*125.00	Cylinder Block Assy. with Pistons, Connecting Rods and Valves	1	39-42	
74120-S		Plug (Expansion)-Rear of Cylinder Block .	1	39-42	
88146-S		Stud (Screw)-Valve Chamber Cover	2	39-42	
88371-S		Stud (Screw)-Water Pump Housing to Cylinder Block	3	39-42	
88403-S		Stud (Screw)-Manifold to Cylinder Block .	4	39-42	
9N-8115	.20	Drain Plug			
9N-6017	1.60	Cover - Timing Gear Side	1	39-42	
9N-6018	.01	Gasket - Timing Gear Side Cover	1	39-42	
20388-S2		Bolt (Hex Head)-Timing Gear Cover	3	39-42	
34807-S7-8		Washer (Lock)-Timing Gear Cover Bolt	3	39-42	
9N-6019-B	3.50	Cover - Cylinder Front	1	39-42	
B-17552	.03	Plug - Cylinder Front Cover	2	39-42	
9N-6020	.02	Gasket - Cylinder Front Cover	1	39-42	
20388-S2		Bolt (Hex Head)-Cylinder Front Cover Plate	6	39-42	
34807-S7-8		Washer Cylinder Front Cover Plate	6	39-42	
9N-6022	.04	Gasket - Governor to Cylinder Timing Gear Cover Side	1	39-42	
9N-6043	.03	Plug (Front)-Engine Block Oil Pipe	2	39-42	
9N-6050-B	6.00	Cylinder Head	1	39-42	
9N-6051	.60	Gasket - Cylinder Head	1	39-42	
351025-S7-8		Nut (Hex)-Cylinder Head Stud	18	39-42	
99A-6055	1.65	Sleeve - Cylinder Block	4	39-42	
40-6057-B	.20	Insert, Intake Valve	4	39-42	
52-6057-B	.20	Insert, Exhaust Valve	4	39-42	
9N-6066	.03	Stud (Short)-Cylinder Head	15	39-42	
18-6066	.04 3.00C	Stud (Medium)-Cylinder Head	1	39-42	
48-6067	.04 3.00C	Stud (Long)-Cylinder Head	2	39-42	
99A-6110-A	1.65	Piston (Standard)	4	39-42	
99A-6135-A	.30	Pin - Piston	4	39-42	
78-6140	.01 .40C	Retainer - Piston Pin	8	39-42	
99A-6150-A	.10	Ring - Piston	8	39-42	
99A-6153-A	.15	Ring - Piston Oil Control	4	39-42	
9N-6200	2.75	Rod - Connecting Assy.	4	39-42	
9N-6211-A	.25	Liner - Connecting Rod Bearing - Std. ...	8	39-42	
9N-6211-B	.25	Liner - Connecting Rod Bearing - .001 U.S.	8	39-42	
9N-6211-C	.25	Liner - Connecting Rod Bearing - .002 U.S.	8	39-42	
9N-6211-D	.25	Liner - Connecting Rod Bearing - .005 U.S.	8	39-42	
18-6212	.05 4.20C	Nut - Connecting Rod	8	39-42	
352250-S		Pin (Cotter) - Connecting Rod-Special ...	8	39-42	
9N-6250-B	5.00	Camshaft	1	39-42	
11A-6256	3.35	Gear, Camshaft			
350400-S		Bolt - Camshaft Gear to Camshaft	4	39-42	
91A-6258	.05	Lock Ring	1	39-42	
91A-6266	.12	Seal - Camshaft Rear Bearing	1	39-42	
9N-6271	.70	Bushing - Camshaft, Front	1	39-42	
9N-6272	1.10	Bushing - Camshaft, Center and Rear	2	39-42	
9N-6303	18.50	Crankshaft	1	39-42	
48-6306	1.10	Gear - Crankshaft	1	39-42	
74156-S		Key (Woodruff)	1	39-42	
40-6310	.07	Slinger - Crankshaft Oil	1	39-42	
9N-6312	1.55	Pulley Assy. - Crankshaft	1	39-42	
B-6319-A	.30	Ratchet - Crankshaft	1	39-42	
9N-6325	.95	Cap - Crankshaft Bearing (Rear)	1	39-42	

* Not subject to regular discount.

FORD TRACTOR PARTS PRICE LIST



Part No.	Price	Part Name	Unit	Year	Remarks
ENGINE (CONT'D)					
9N-6330	\$.95	Cap - Crankshaft Bearing (Center)	1	39-42	
9N-6331-A	.80	Liner - Std. - Main Bearing (Center)	2	39-42	
9N-6331-B	.80	Liner - Main Bearing (Center) .001 U.S. .		39-42	
9N-6331-C	.80	Liner - Main Bearing (Center) .002 U.S. .		39-42	
9N-6331-D	.80	Liner - Main Bearing (Center) .005 U.S. .		39-42	
9N-6333-A	.40	Liner - Std. - Main Bearing Front and Rear.	4	39-42	
9N-6333-B	.40	Liner - Main Bearing (Front & Rear) .001 U.S.		39-42	
9N-6333-C	.40	Liner - Main Bearing (Front & Rear) .002 U.S.		39-42	
9N-6333-D	.40	Liner - Main Bearing (Front & Rear) .005 U.S.		39-42	
91A-6335	.25	Seal - Crankshaft Rear Bearing Oil	1	39-42	
9N-6345	.15	Stud (Short)-Main Bearing Cap	5	39-42	
9N-6346	.20	Stud (Long)-Main Bearing Cap	1	39-42	
B-6348	.07	Nut (Castle) 1/2 - 20 Special	6	39-42	
9N-6375	7.50	Fly Wheel and Ring Gear Assy.	1	39-42	
350645-S		Bolt (Hex Head)-Flywheel to Crankshaft ..	4	39-42	
9N-6384	1.40	Gear - Flywheel Starting	1	39-42	
B-6387	.04	Dowel - Flywheel to Crankshaft	2	39-42	
18-6397	.04	Dowel - Cylinder Block to Transmission and Front Cover	4	39-42	
18-6500-A4	.25	Push Rod - Valve	8	39-42	
9N-6505	.50	Valve - Exhaust	4	39-42	
11A-6505	.55	Valve - Intake	4	39-42	
40-6510-A	.30pr	Bushing - Valve Guide	16	39-42	
40-6512	.02 1.55C	Retainer - Valve Guide Bushing	8	39-42	
78-6513	.15	Spring - Valve	8	39-42	
40-6514-B	.03 2.50C	Retainer - Valve Spring	8	39-42	
9N-6520	.25	Cover - Valve Chamber	2	39-42	
9N-6521	.10	Gasket - Valve Chamber Cover	2	39-42	
88146-S		Stud (Screw)-Valve Chamber Cover	2	39-42	
33798-S7		Nut (Hex)-Valve Chamber	2	39-42	
34806-S7		Washer (Lock)-Valve Chamber Cover Stud ..	2	39-42	
9N-6603	2.90	Body Assy. - Oil Pump	1	39-42	
9N-6608	2.10	Drive Gear and Shaft Assy. - Oil Pump ...	1	39-42	
52-6610-B	.55	Gear - Oil Pump Driven	1	39-42	
9N-6612	.08	Bushing - Oil Pump Body	1	39-42	
52-6614-B	.55	Gear - Oil Pump Driving	1	39-42	
9N-6615	2.50	Screen Cover Assy. - Oil Pump	1	39-42	
22503-S		Bolt (Hex Head) - Oil Pump Cover	3	39-42	
9N-6619	.01	Gasket - Oil Pump Cover	1	39-42	
01A-6654	.01	Spring - Oil Relief Valve	1	39-42	
01A-6663	.01	Plunger - Oil Relief Valve	1	39-42	
68-6666	.06	Nut - Oil Relief Valve	1	39-42	
40-12410	.01	Gasket - Oil Relief Valve			
9N-6675	30.70	Pan-Oil	1	39-42	
72038-S		Pin (Cotter) (Drain Hole)	1	39-42	
B-6700	.08	Packing - Oil Pan and Cylinder Front Cover	2	39-42	
9N-8115	.20	Plug (Oil Pan Drain)	1	39-42	
91A-6701	.10	Packing - Oil Pan Rear	2	39-42	
9N-6710	.12	Gasket - Oil Pan R.H.	1	39-42	
9N-6711	.12	Gasket - Oil Pan L.H.	1	39-42	
20366-S2		Bolt (Hex Head) Oil Pan to Block Bolt ...	13	39-42	
20376-S7-8		Bolt - Oil Pan to Front Cover	3	39-42	
34806-S7-8		Washer (Lock)-Engine Pan to Block Bolts .	16	39-42	
9N-6730	1.10	Plug and Screen Assy. - Oil Drain	1	39-42	
91A-6734	.04	Gasket - Drain Plug	1	39-42	
9N-6750-A	.10	Indicator - Oil Level	1	39-42	
9N-6754		Tube-Oil Level Indicator (Service 9N-7020)			
9N-6763	.45	Pipe Assy. - Oil Filler	1	39-42	
9N-6766	.30	Cap Assy. - Oil Filler	1	39-42	



FORD TRACTOR PARTS PRICE LIST

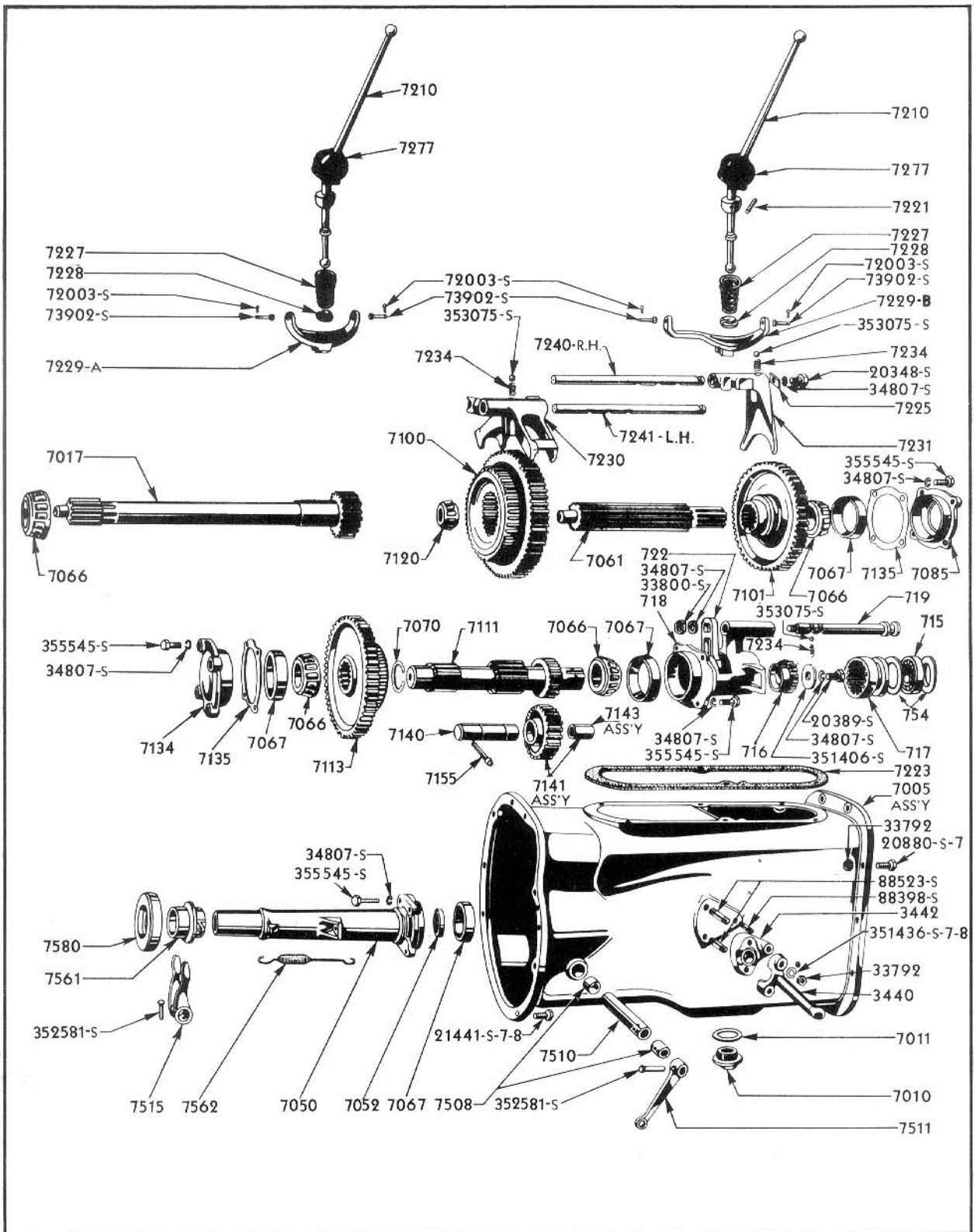

FORD TRACTOR PARTS PRICE LIST



Part No.	Price	Part Name	Unit	Year	Remarks
TRANSMISSION					
9N-7000	*\$125.00	Transmission Assy.	1	39-42	
21441-S7		Bolt (Hex Head)-Transmission Housing to Engine Assy.	9	39-42	
20880-S7-8		Bolt (Hex Head)-Transmission to Center Housing	9	39-42	
33792-S7-8-18		Nut (Hex)-Transmission to Center Housing			
9N-7005-B	55.00	Case Assy. - Transmission	1	39-42	After Tr. 9N-47507 ...
9N-7010	.55	Plug (Drain)-Transmission	3	39-42	
9N-7011	.02	Gasket - Transmission Drain Plug	3	39-42	
9N-7017-A	7.80	Gear - Transmission Main Drive	1	39-42	
9N-7020	.15	Tube (Short)-Transmission Oil Level Indicator	1	39-42	
9N-7021	.25	Tube (Long)-Transmission Oil Level Indicator	1	39-42	
9N-7050	3.40	Retainer - Transmission Main Drive Gear Bearing	1	39-42	
355545-S		Bolt (Hex Head)-Transmission Retainer ...	4	39-42	
34807-S7-8		Washer (Lock)-Transmission Retainer Bolt.	4	39-42	
78-7052	.30	Seal - Oil, Transmission Main Drive Gear Bearing		39-42	
9N-7061	4.00	Shaft (Main)-Transmission	1	39-42	
9N-7066	1.45	Cone and Roller Assy. - Transmission Main and Countershaft Bearing	4	39-42	
9N-7067	.80	Cup - Transmission Main and Countershaft Bearing	4	39-42	
9N-7070	.05	Ring (Snap)-Transmission Countershaft ...	1	39-42	
9N-7085	.95	Retainer - Transmission Main Shaft Bearing	1	39-42	
355545-S		Bolt (Hex Head)-Transmission Retainer ...	4	39-42	
34807-S7-8		Washer (Lock)-Transmission Retainer Bolt.	4	39-42	
9N-7086	.01	Gasket - Transmission Bearing Retainer ..	2	39-42	
9N-7100	15.00	Gear (Sliding)-Transmission Low and High.	1	39-42	
9N-7101	12.50	Gear (Sliding)-Transmission Second and Reverse	1	39-42	
9N-7111	10.00	Countershaft-Transmission	1	39-42	
9N-7113-A	15.00	Gear - Transmission Countershaft	1	39-42	
9N-7120	1.40	Bearing Assy. - Transmission Pilot	1	39-42	
9N-7134	1.00	Retainer-Transmission Countershaft Bearing	1	39-42	
355545-S		Bolt (Hex Head)-Transmission Retainer ...	4	39-42	
34807-S7-8		Washer (Lock)-Transmission Retainer Bolt.	4	39-42	
9N-7135-A	.04	Shim - Transmission Bearing Retainer .003	2	39-42	
9N-7135-B	.04	Shim - Transmission Bearing Retainer .004	2	39-42	
9N-7135-C	.04	Shim - Transmission Bearing Retainer .007	2	39-42	
9N-7135-D	.04	Shim - Transmission Bearing Retainer .010	2	39-42	
9N-7135-E	.04	Shim - Transmission Bearing Retainer .020	2	39-42	
9N-7137-A	.15	Indicator (Oil Level)-Transmission	1	39-42	
9N-7137-B	.15	Indicator (Oil Level) - Transmission		40-42	After Tr. #47508 ..
9N-7140	.75	Shaft - Reverse Idler Gear	1	39-42	
9N-7141	3.25	Gear and Bushing Assy. - Reverse Idler ..	1	39-42	
9N-7143	.35	Bushing - Transmission Idler Gear	1	39-42	

* Not subject to regular discount.



FORD TRACTOR PARTS PRICE LIST

Part No.	Price	Part Name	Unit	Year	Remarks
TRANSMISSION (CONT'D)					
9N-7155	\$.05	Pin (Retaining)-Transmission Reverse Idler Shaft	1	39-42	
9N-7158-A	1.00	Side Cover Assy.	1	39-42	
21440-S7		Bolt (Hex Head)-Differential Housing		39-42	
		Cover (Side)	4	39-42	
21441-S7		Bolt (Hex Head)-Differential Housing		39-42	
		Side Cover and Brake Sector	2	39-42	
9N-7210	2.40	Lever (Shift)-Transmission Gear	1	39-42	
9N-7221	.02	Pin - Gear Shift Lever	1	39-42	
9N-7223-A	.15	Gasket - Gear Shift Housing (on 7005-A Housing)	1	39-42	{ Before Tractor #47508 After Tractor #47507
9N-7223-B	.15	Gasket - Gear Shift Housing	1	39-42	
9N-7225	.05	Plate - Gearshift Fork Rod	1	39-42	
20348-S7		Bolt (Hex Head)-Shift Rod Anchor	1	39-42	
34807-S7-8		Washer (Lock)-Shift Rod Anchor Bolt	1	39-42	
9N-7227	.15	Spring - Shifter Lever	1	39-42	
9N-7228	.30	Seat - Gear Shift Lever Spring	1	39-42	
9N-7229-A	1.00	Lock - Gear	1	39-42	
9N-7229-B	1.00	Lock - Gear	1	39-42	
73902-S		Pin (Clevis)-Steering Gear	2	39-42	
72003-S7-8		Pin (Cotter)-Drag Link Clamp	2	39-42	
9N-7230-A	4.00	Fork (Shifter)-Transmission Low and High Gear	1	39-42	
9N-7230-B	4.50	Fork (Shifter)-Transmission Low and High Gear	1	39-42	
9N-7231-A	3.10	Fork (Shifter)-Transmission Second and Reverse	1	39-42	
9N-7231-B	3.10	Fork (Shifter)-Transmission Second and Reverse	1	39-42	
79-7234	.02	Spring - Shifter Fork	2	39-42	
353075-S		Ball (Steel)-Transmission Shifter Fork ..	2	39-42	
9N-7240	1.00	Rod - Transmission Selector R.H.	1	39-42	
9N-7241	1.00	Rod - Transmission Selector L.H.	1	39-42	
9N-7277	.18	Seal (Dust)-Gear Shift Lever	1	39-42	
9N-7334	.80	Rod Assy. - Clutch Release	1	39-42	
33800-S7-8		Nut (Hex)-Clutch Release Rod	1	39-42	
97013-S		Clevis (Adjustable)-Clutch Release Rod ..	1	39-42	
73912-S7		Pin (Clutch Release Rod Clevis)	2	39-42	
9N-7503	1.35	Shaft and Arm Assy. - Clutch Release	1	39-42	
9N-7508	.15	Bushing - Clutch Pedal	1	39-42	
40-7508	.07	Bushing - Clutch Release Shaft	1	39-42	
B-7510	.55	Shaft (Release)-Clutch	1	39-42	
353027-A2-S7-8		Fitting (Lubrication)-Clutch Release Shaft	1	39-42	
9N-7511	.75	Arm - Clutch Release Shaft	1	39-42	
352581-S7-8		Pin (Special Flat Head)-Clutch Release ..		39-42	
		Shaft to Arm	1	39-42	
48-7515	.40	Fork - Clutch Release Shaft	1	39-42	
352581-S7-8		Pin (Special Flat Head)-Clutch Release ..		39-42	
		Shaft to Fork	1	39-42	
9N-7520	4.50	Pedal-Clutch	1	39-42	
9N-7530	1.00	Rod and Yoke Assy. (Release)-Clutch	1	39-42	
72010-S		Pin (Cotter)-Clutch Rod Clevis	2	39-42	
73912-S7		Pin (Clevis)-Clutch Pedal	2	39-42	
97013-S		Clevis Rod and Yoke - Clutch Release Assy.	1	39-42	
33800-S7-8		Bolt Rod and Yoke - Clutch Release Assy..	1	39-42	

FORD TRACTOR PARTS PRICE LIST



Part No.	Price	Part Name	Unit	Year	Remarks
TRANSMISSION (CONT'D)					
40-7549	\$.45	Facings - Clutch Disc	2	39-42	
351926-S		Rivet (Flat Head C'sunk)-Clutch Disc	24	39-42	
91A-7550	3.85	Disc Assy. - Clutch	1	39-42	
60006-S		Rivet (Flat Head)-Clutch Disc Assy.	6	39-42	
9N-7561	.75	Hub - Clutch Release Bearing	1	39-42	
9N-7562	.08	Spring - Clutch Release Bearing	2	39-42	
09A-7563	5.25	Pressure Plate and Cover Assy. Clutch ...	1	39-42	
350433-S		Screw (Hex Head)-Clutch to Flywheel	6	39-42	
34806-S7-8		Washer (Lock)-Clutch to Flywheel Bolt ...	6	39-42	
78-7580	1.75	Bearing Assy. - Clutch Release	1	39-42	
B-7600-A	1.25	Bearing - Clutch Pilot	1	39-42	
B-7609	.03	Retainer - Flywheel Dowel	1	39-42	

RADIATOR AND GRILLE

9N-8005	22.00	Radiator Assy.	1	39-42	
21442-S7		Bolt (Hex Head)-Radiator to Support	2	39-42	
351436-S7-8		Washer (Lock)-Radiator to Support Bolt ..	2	39-42	
9N-8032	.35	Pad - Radiator Filler Neck	1	39-42	
9N-8100	.95	Cap Assy. - Radiator	1	39-42	
9N-8115	.20	Cock (Drain)-Radiator	1	39-42	
40-8125	.01	Anti-Squeak - Radiator to Bracket	2	39-42	
9N-8206-D	9.90	Grille - Radiator (Steel)	1	39-42	
20311-S7		Bolt (Hex Head)-Grille to Support	2	39-42	
33798-S7-8		Nut (Hex)-Grille to Support	2	39-42	
34806-S7-8		Washer (Lock)-Grille to Support	2	39-42	
9N-8215	.30	Ornament - Radiator	1	39-42	
33795-S7		Nut (Hex)-Name Plate to Grille	1	39-42	
350835-S7		Nut (Speed)-Name Plate to Grille	1	39-42	
9N-8260	.25	Hose - Radiator	1	39-42	
9N-8286	.55	Hose - Radiator Outlet to Water Pump	1	39-42	
60-8287	.05	Clamp Assy. - Radiator Hose	4	39-42	
27153-S7		Screw (Round Head)-Hose Clamp Assy.	4	39-42	
34141-S7-8		Nut (Square)-Hose Clamp Assy. Screw	4	39-42	
9N-8430-B	.07	Support - Radiator Grille Lower	2	39-42	
20318-S7		Bolt (Hex Head)-Grille Bracket to Radiator Bracket	4	39-42	
33798-S7-8		Nut (Hex)-Grille Bracket to Radiator Bracket Bolt	4	39-42	
34706-S7-8		Washer (Flat)-Grille Bracket to Radiator Support	4	39-42	
34806-S7-8		Washer (Lock)-Grille Bracket to Radiator Support Bolt	4	39-42	
9N-8032	.35	Pad - Weather	1	39-42	

WATER PUMP

(See Illustration on Page 28)

9N-8501	7.75	Water Pump Assy.	1	39-42	
9N-8505	2.50	Housing - Water Pump	1	39-42	
20318-S7		Bolt (Hex Head)-Water Pump Housing to Cylinder Block	1	39-42	
88371-S		Stud (Screw)-Water Pump Housing to Cylinder Block	3	39-42	
33798-S7-8		Nut (Hex) Water Pump Stud	3	39-42	
34806-S7-8		Washer (Lock)-Water Pump Housing to Cylinder Block	4	39-42	
9N-8507	.03	Gasket - Water Pump	1	39-42	
9N-8508	.15	Cover - Water Pump	1	39-42	
78-8512	.40	Impeller - Water Pump	1	39-42	



FORD TRACTOR PARTS PRICE LIST

Part No.	Price	Part Name	Unit	Year	Remarks
WATER PUMP (CONT'D)					
34805-S7		Washer (Lock) - Fan to Fan Pulley	4	39-42	
9N-8606	\$2.25	Pulley - Fan	1	39-42	
9N-8620-A	1.00	Belt - Fan for A & B Generator	1	39-42	
9N-8620-B	1.00	Belt - Fan (Long, for C Generator)	1	39-42	

FUEL SYSTEM

9N-9002-A	9.25	Fuel Tank Assy.	1	39-42	
20337-S7		Bolt (Hex Head) - Fuel Tank to Fuel Tank Support	3	39-42	
34706-S7-8		Washer (Flat) - Fuel Tank to Fuel Tank Support	3	39-42	
34806-S7-8		Washer (Lock) - Fuel Tank to Fuel Tank Support	3	39-42	
33798-S7-8		Nut (Hex) - Fuel Tank to Fuel Tank Support Bolt	3	39-42	
9N-9030	.20	Cap Assy. - Fuel Tank Filler	2	39-42	
9N-9067	.05	Pad - Fuel Tank Support	3	39-42	
9N-9121	.10	Anti-Rattler - Fuel Line	1	39-42	
9N-9126	1.75	Adaptor-Tank to Tank Support	1	39-42	
9N-9155-A	1.80	Sediment Bulb Assy. -	1	39-42	
9N-9160	.04	Gasket - Sediment Bulb	1	39-42	
9N-9161	.10	Screen - Sediment Bulb	1	39-42	
9N-9162	.15	Glass Bowl - Sediment Bulb	1	39-42	
9N-9164-A	1.65	Valve Body Assy. - Sediment Bulb	1	39-42	
356392-S		Washer - Valve Body Assy.	1	39-42	
356390-S		Washer - Valve Body Assy.	1	39-42	
357244-S		Cotter Pin - Valve Body Assy.	1	39-42	
9N-9166	.15	Clamps, Wire and Screen Assy. - Sediment Bulb	1	39-42	
9N-9273	1.45	Gauge Assy. - Oil Pressure	1	39-42	
34079-S7		Nut (Hex) - Oil Pressure Gauge to Dash ..	2	39-42	
34843-S7		Washer (Lock) - Oil Pressure Gauge to Dash.	2	39-42	
9N-9282-A	.30	Fuel Line Assy.	1	39-42	
91A-2133	.03	Nut - Fuel Line Assy.	2	39-42	

MANIFOLD

9N-9425	4.90	Manifold - Intake and Exhaust	1	39-42	
88403-S		Stud (Screw) - Exhaust Manifold	4	39-42	
33816-S		Nut (Hex) - Exhaust Manifold Studs	4	39-42	
351436-S7-		Washer (Lock) - Manifold	4	39-42	
9N-9447	.02	Gasket - Carburetor to Manifold	1	39-42	
9N-9448	.05	Gasket - Intake and Exhaust Manifold	2	39-42	

CARBURETOR

9N-9510-A	8.80	Carburetor Assy.	1	39-42	
20356-S7		Bolt (Hex Head) - Manifold to Carburetor.	2	39-42	
34806-S7-8		Washer (Lock) - Manifold to Carburetor Bolt	2	39-42	
9N-9447	.02	Gasket - Carburetor to Manifold	1	39-42	
9N-9511	4.25	Bowl, Carburetor Assy. (Body and Plugs) .	1	39-42	

FORD TRACTOR PARTS PRICE LIST



Part No.	Price	Part Name	Unit	Year	Remarks
CARBURETOR (CONT'D)					
9N-9515	\$4.35	Throttle Body Assy.	1	39-42	
34804-S2		Washer (Lock) - Bowl Cover to Body No. 12.	4	39-42	
355245-S		Screw - Bowl Cover to Body	4	39-42	
9N-9519	.05	Gasket - Between Upper and Lower Body ...	1	39-42	
9N-9530	.55	Nozzle - Carburetor (Main)	1	39-42	
9N-9533	.20	Jet - Maximum Fuel Limiting	1	39-42	
9N-9536-A	.15	Ratchet Assy. - Main Adjustment	1	39-42	
356181-S		Washer (Lock) - Main Adjustment Ratchet Assy.	2	39-42	
9N-9539	.15	Spring (Choke Return) - Carburetor	1	39-42	
9N-9540-A	.10	Spring - Main Adjustment Needle	1	39-42	
9N-9541	.25	Needle - Idling Adjusting	1	39-42	
9N-9546-A	.50	Choke Lever and Shaft Assy.	1	39-42	
9N-9549	.65	Choke Fly Assy.	1	39-42	
356181-S		Washer (Lock) - Main Air Choke Plate ...	2	39-42	
355001-S7-8		Screw (Machine) - Main Air Choke Plate ..	2	39-42	
9N-9550-A	1.10	Float and Lever Assy.	1	39-42	
9N-9553	.45	Strainer and Elbow Assy.	1	39-42	
9N-9558-A	.05	Shaft - Carburetor Float Lever	1	39-42	
9N-9563-A	.05	Gasket - Adjusting Needle Seat Plug	1	39-42	
9N-9564	1.10	Seat and Valve Assy. - Matched Float ...	1	39-42	
9N-9565-A	.45	Needle Assy. - Main Adjustment	1	39-42	
356211-S7		Washer (Flat) - Main Adjustment Needle ..	1	39-42	
9N-9578	.15	Spring - Idle Adjustment Needle	1	39-42	
9N-9581-A	.75	Throttle Shaft and Lever Assy.	1	39-42	
31660-S7		Screw (Adjusting) Throttle	1	39-42	
9N-9585-A	.20	Throttle Fly - Carburetor	1	39-42	
356181-S		Washer (Lock) - Carburetor Throttle Fly .	2	39-42	
355000-S		Screw (Machine) - Carburetor Throttle Fly	2	39-42	
9N-9586-A	.35	Venturi	1	39-42	
355000-S		Screw - Carburetor Throttle Plate	2	39-42	
9N-9588	.05	Screw - Carburetor Throttle Fly	2	39-42	
9N-9589	.10	Spring - Throttle Lever Adjustment Screw.	1	39-42	
9N-9591	.10	Retainer - Throttle Shaft Packing	1	39-42	
9N-9596	.20	Jet - Idler	1	39-42	
9N-9608	.05	Gasket - Pump Check Valve Screw	1	39-42	
9N-9610	.10	Screw - Carburetor Throttle Adjustment ..	1	39-42	
9N-9622-A	.05	Packing - Throttle Shaft	1	39-42	
9N-9819-A	.10	Pin - Throttle Control Lever	1	39-42	
9N-9914	.15	Jet - Economizer	1	39-42	
355305-S		Screw (Headless) - Idle Drilling Plug ...	1	39-42	
9N-18376	.30	Gasket Kit - Carburetor	1	39-42	

AIR CLEANER

9N-9600-C2	7.00	Air Cleaner Assy.	1	39-42	
21440-S7		Bolt (Hex Head) Air Cleaner Upper Steering Housing	2	39-42	
351436-S7-8		Washer Lock Spl.	2	39-42	
9N-9602-C1	.70	Cover Assy. - Air Cleaner (Donaldson) ...	1	39-42	
9N-9602-C2	.30	Cover Assy. - Air Cleaner (U.S.)	1	39-42	

FORD TRACTOR PARTS PRICE LIST

Part No.	Price	Part Name	Unit	Year	Remarks
AIR CLEANER (CONT'D)					
355940-S7		Nut (Special Wing) - Air Cleaner Cover ..	1	39-42	
9N-9609-C1	\$ 5.00	Body Assy. - Air Cleaner (Donaldson)	1	39-42	
9N-9609-C2	5.25	Body Assy. - Air Cleaner (U.S.)	1	39-42	
9N-9619-C1	.25	Screen (Inner) - Air Cleaner (Donaldson) .	1	39-42	
9N-9619-C2	.05	Screen (Inner) - Air Cleaner (U.S.)	1	39-42	
9N-9623	.02	Gasket - Air Cleaner	1	39-42	
9N-9628-C1	.65	Clamp Assy. - Air Cleaner (Donaldson) ...	1	39-42	
9N-9628-C2	.30	Clamp Assy. - Air Cleaner (U.S.)	1	39-42	
9N-9652	.10	Hose - Air Cleaner to Carburetor	2	39-42	
9N-9653	.04	Clamp - Air Cleaner to Carburetor Hose ..	4	39-42	
9N-9658-C1	1.50	Oil Cup Assy. - Air Cleaner (Donaldson) ..	1	39-42	
9N-9658-C2	.90	Oil Cup Assy. - Air Cleaner (U.S.)	1	39-42	
9N-18215-C	1.00	Pipe - Air Cleaner to Carburetor	1	39-42	

THROTTLE CONTROLS

9N-9700-A	.15	Rod Assy. - Choke Control	1	39-42	
9N-9703	.20	Knob - Choke	1	39-42	
9N-9802	2.20	Shaft Assy. - Throttle Control	1	39-42	
9N-9805	1.45	Rod - Throttle Control	1	39-42	
9N-9806	.02	Spring - Throttle Control Rod	1	39-42	
9N-9807	.70	Lever - Throttle Control (Short)	1	39-42	
9N-9810	.20	Socket Assy. - Throttle Control Rod	1	39-42	
9N-9812	.06	Retainer - Throttle Control Rod Spring ..	1	39-42	
9N-9815-B	.30	Rod Assy. - Throttle Shaft to Governor ..	1	39-42	
9N-9818-A	.15	Rod - Governor to Carburetor	1	39-42	
9N-9820	.60	Quadrant - Throttle Control Rod	1	39-42	
20346-S7		Bolt (Hex Head) - Throttle Control Quad- rant to Upper Steering Gear Housing .	2	39-42	
9N-9824	.06	Bracket - Throttle Control Shaft	1	39-42	
9N-9827	.04	Governor Compensating Spring	1	39-42	
9N-9828	.05	Pin - Throttle Control Shaft Bracket	1	39-42	

GENERATOR

9N-10000-C	16.50	Generator Assy. (Heavy Duty)	1	39-42	
20887-S7		Bolt - Generator to Engine	1	39-42	
33792-S7-8-18		Nut - Generator to Engine Bolt	1	39-42	
34808-S7-8		Washer - Generator to Engine Bolt.....	1	39-42	
9N-10005-C	6.45	Armature Assy. - Generator	1	39-42	
9N-10036	.06	Wire Assy. - Generator	1	39-42	
31027-S7		Screw - General Field Coil to Brush	2	39-42	
34902-S7-8		Washer	5	39-42	

FORD TRACTOR PARTS PRICE LIST

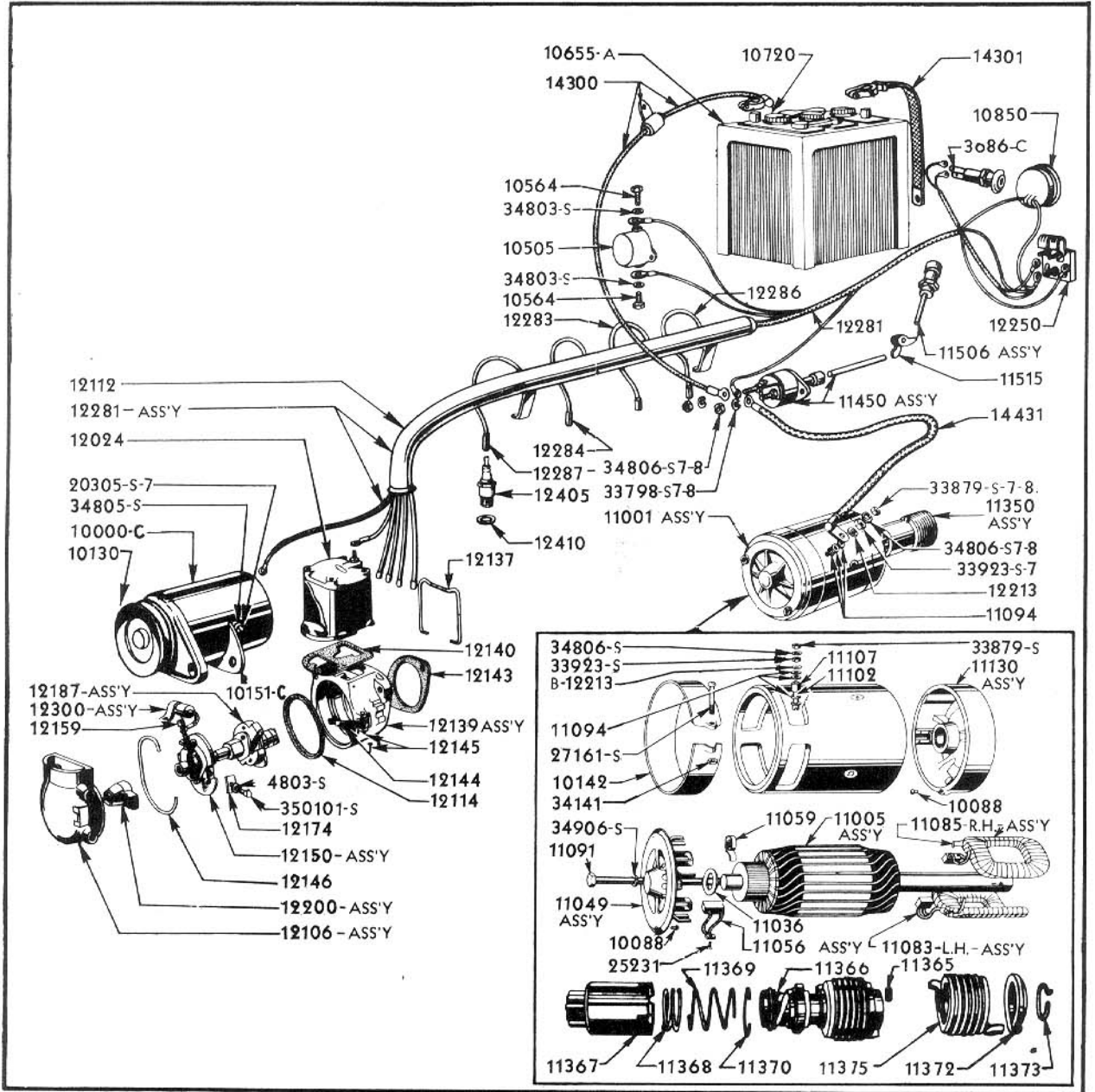

FORD TRACTOR PARTS PRICE LIST

Part No.	Price	Part Name	Unit	Year	Remarks
GENERATOR (CONT'D)					
68-10044	\$.01	Screw - Pole Piece	2	39-42	
9N-10050-C	2.10	End Plate Assy. - Generator	1	39-42	
31588-S7		Screw (Fillister Head) - Generator Brush			
		Terminal to End Plate No. 10	1	39-42	
34803-S7-8		Washer (Lock) - Generator Brush Terminal			
		to End Plate Screw No. 10	1	39-42	
40-10051	.02	Brush Holder - Generator	3	39-42	
9N-10057	.04	Spring - Generator Brush	3	39-42	
40-10057	.02	Spring - Brush Holder	3	39-42	
9N-10069-A	.25	Fixed Brush and Terminal Wire Assy. -			
		Generator	3	39-42	
9N-10069-B	.25	Brush and Terminal Wire Assy. - Generator	3	39-42	
40-10069	.10	Brush - Generator	2	39-42	
40-10070	.20	Brush - Generator (adj.)	1	39-42	
31061-S7		Screw - Generator Brush Holder	3	39-42	
34902-S7-8		Washer	3	39-42	
18-10088	.01	Dowel - Generator and Starter Frame	2	39-42	
9N-10096-A	.01	Ring - Generator Pulley Retaining	1	39-42	
9N-10096-B	.01	Ring - Generator Pulley Retaining	1	39-42	
9N-10120	.04	Bolt (Through) - Generator	2	39-42	
34803-S7-8		Washer (Lock) - Generator End Plate and			
		Frame Assembly No. 10	2	39-42	
18-10120-A	.04	Bolt - Generator (through)	2	39-42	
34803-S7-8		Lock Washer	2	39-42	
9N-10129-B	1.65	Generator Brush End Plate Assembly	1	39-42	
9N-10130-B	1.50	Pulley - Generator (For C Generator)	1	39-42	
9N-10130-C	1.60	Pulley - Generator (For A Generator)	1	39-42	
9N-10130-D	1.50	Pulley - Generator (For B Generator)	1	39-42	
351080-S		Nut - Generator Pulley	1	39-42	
74142-S		Key (Woodruff) - Generator Pulley to Shaft	1	39-42	
9N-10138-C	3.15	Plate Assy. - Generator Front End	1	39-42	
B-10141	.04	Cup - Generator Oil	1	39-42	
18-10146	.01	Retainer - Wick	1	39-42	
9N-10147	.02	Wick - Generator Brush End Plate	1	39-42	
9N-10151-C	.12	Support - Generator	1	39-42	
20305-S7-8		Bolt - Generator Support			
34805-S7		Washer - Generator Support	2	39-42	
9N-10175-C	1.60	Field Coil Assy. - Generator	1	39-42	
81A-10208	.01	Insulator - Terminal Inner	1	39-42	
81A-10211	.01	Screw - Generator Terminal No. 10-32	1	39-42	
34703-S7		Washer (Flat) - Generator Terminal Screw			
		No..10	2	39-42	
34079-S7		Nut (Hex) - Generator Terminal Screw	2	39-42	
34803-S7-8		Washer (Lock) - Generator Terminal Screw			
		No. 10	2	39-42	
9N-10505-B	\$ 1.85	Cut Out Assy. - Generator	1	39-42	
20306-S7		Bolt (Hex Head) Cut Out to Dash	2	39-42	
34806-S7-8		Washer - Lock	2	39-42	

FORD TRACTOR PARTS PRICE LIST



Part No.	Price	Part Name	Unit	Year	Remarks
BATTERY					
(See Illustration on Page 33)					
9N-10597	.35	Cutout Plate	1	39-42	
27058-S7-8		Screw	1		
34803-S7-8		Lock Washer	1		
340790-S7-8		Nut	1	39-42	
20311-S7		Bolt	2	39-42	
33798-S7-8		Nut	2	39-42	
34806-S7-8		Washer	2	39-42	
9N-10655-A	*8.75	Battery Assy. - 13 Plate	1	39-42	
81A-10720	.07	Plug (Filler) - Battery	3	39-42	
9N-10724	.25	Strap Assy. (Hold Down) Battery	1	39-42	
01A-10726	.08	Insulator - Battery Hold Down Strap	1	39-42	
9N-10728-B	.40	Bar - Battery Clamp Hold Down	2	39-42	
34171-S7-8		Nut (Blind) - Battery Hold Down Strap to Dash	2	39-42	
34746-S7-8		Washer (Flat) - Battery Hold Down Strap to Dash	2	39-42	
9N-10729	.15	End Piece - Battery Hold Down Strap	1	39-42	
9N-10737	.75	Plate - Battery Cover	1	39-42	

AMMETER

(See Illustration on Page 16)

9N-10850-B	2.45	Ammeter Assy.	1	39-42	
350860-S		Nut (Hex Brass) - Ammeter to Rear Bolt No. 10	2	39-42	

STARTER AND DRIVE

(See Illustration on Page 33)

9N-11001	14.25	Starter and Drive Assy.	1	39-42	
9N-11002	10.00	Starter Assy. (Only)	1	39-42	
18-10142	.05	Band - Starter Cover	1	39-42	
27161-S7		Screw (Round Head Machine) - Starter Cover Band	1	39-42	
34141-S7-8		Nut (Square) - Starter Cover Band Screw No. 10-32	1	39-42	
52-11005	3.65	Armature Assy. - Starter	1	39-42	
18-11036	.01	Washer (Thrust) - Starter Armature	2	39-42	
18-11049	.75	End Plate Assy. - Starter Brush	1	39-42	
18-11056	.15	Brush Assy. Starter (Grounded)	2	39-42	
25231-S7		Screw (Fillister Head Machine) - Starter Brush Assy. to Frame	2	39-42	
B-11059	.03	Spring - Starter Brush	4	39-42	
18-11083	.65	Field Coil - Starter L.H.	1	39-42	
18-11085	.65	Field Coil - Starter R.H.	1	39-42	
18-11091	.03	Bolt (Through) Starter	2	39-42	

* Not subject to regular discount.



FORD TRACTOR PARTS PRICE LIST

Part No.	Price	Part Name	Unit	Year	Remarks
STARTER AND DRIVE (CONT'D)					
34906-S2		Washer (Internal Tooth) Starter through Bolt	2	39-42	
18-11094	\$.01	Washer - Starter Field Terminal	3	39-42	
18-11102	.05	Terminal - Starter Field	1	39-42	
34806-S7-8		Washer (Lock)-Starter Field Terminal Post	1	39-42	
33923-S7		Nut (Hex) - Starter Field Terminal Check Nut	1	39-42	
33879-S7		Nut (Hex) - Starter Field Terminal Post	1	39-42	
18-11107	.03	Bushing - Starter Terminal	1	39-42	
52-11130	.85	Plate Assy. - Starter (Rear End)	1	39-42	
82A-11140-B	.02	Bracket - Starter to Oil Pan	1	39-42	
52-11350-C	3.50	Drive Assy. - Starter	1	39-42	
52-11365-B	.02	Pin - Pinion	1	39-42	
52-11366-B	2.55	Shaft - Drive Screw	1	39-42	
52-11367	1.90	Pinion and Barrel Drive	1	39-42	
52-11368	.20	Spring - mashing	1	39-42	
52-11369	.12	Spring - Anti Drift	1	39-42	
52-11370	.03	Ring - Pinion and Barrel Retainer	1	39-42	
52-11372	.25	Plate - Anchor Spring	1	39-42	
52-11373	.05	Ring (Lock) - Spring	1	39-42	
52-11375	.60	Spring - Starter Drive	1	39-42	
9N-11450-A	.70	Switch - Starter Assy. (In Dash)	1	39-42	
9N-11450-B	1.25	Switch - Starter Assy. (Foot Control) ...	1	39-42	
9N-11467	.02	Gasket - Starting Switch	1	39-42	
20310-S7		Bolt (Hex Head) - Starter Button	2	39-42	
33798-S7-8		Nut (Hex) - Starter Switch Assy.	2	39-42	
34806-S7-8		Washer (Lock) - Starter Switch to Steering Gear Housing	2	39-42	
9N-11500	.10	Knob - Starter Switch (Rubber)	1	39-42	
9N-11506	.70	Starter Button Assy.	1	39-42	
40-12410		Gasket	1	39-42	
9N-11511	.05	Rod - Starter Push Lever	1	39-42	
9N-11512	.25	Rod - Starter Push	1	39-42	
72009-S		Pin - (Cotter) Starter Button to Starter Switch Push Rod	1	39-42	
9N-11515	.40	Lever - Starter Push	1	39-42	
9N-11652	.85	Switch Assy. - Lighting With Connector Wires	1	39-42	
9N-11653-B	2.25	Wiring Assy. - Lighting - Less Switch ...	1	39-42	
9N-11664	.05	Plug (Rubber) - Dash	1	39-42	

DISTRIBUTOR AND COIL

(See Illustration on Page 33)

9N-12000	16.25	Distributor and Coil Assy.	1	39-42	
20376-S7-8		Bolt (Hex Head) Distributor to Engine Front Cover	2	39-42	
34806-S7-8		Washer, Lock	2	39-42	
9N-12024	4.00	Ignition Coil Assy.	1	39-42	
350830-S7-8		Nut, Ignition primary post	1	39-42	
9N-12100	12.25	Distributor Assy. Less Coil	1	39-42	
9N-12106	2.30	Housing Assy. - Distributor Terminal (Cap)	1	39-42	
9N-12112	1.25	Conduit - Spark Plug Wires	1	39-42	
9N-12113	.05	Grommet (Seal) - Spark Plug Wire	4	39-42	
91A-12114	.03	Gasket - Distributor Terminal Housing ...	1	39-42	
9N-12137	.03	Bail - Distributor Coil	1	39-42	
9N-12139	2.25	Distributor Base and Clamp Assy.	1	39-42	
91A-12140	.08	Gasket - Distributor Coil	1	39-42	
9N-12143	.02	Gasket - Distributor Base	1	39-42	
9N-12144	.02	Clamp - Distributor Terminal Housing ...	2	39-42	
B-12145	.02	Rivet - Distributor Cap Clamp	2	39-42	

FORD TRACTOR PARTS PRICE LIST



Part No.	Price	Part Name	Unit	Year	Remarks
DISTRIBUTOR AND COIL (CONT'D)					
91A-12146	\$.03	Spring - Distributor Base	1	39-42	
9N-12147	.15	Dist. Vent Cap Assy.	2	39-42	
48-12148	.02	Screw - Distributor to Front Cover	2	39-42	
9N-12150	3.20	Breaker Assy. - Distributor	1	39-42	
9N-12151	2.00	Dist. Bracket Plate Assy.	1	39-42	
91A-12159	.02	Screw (Primary) Contact Distributor	1	39-42	
9N-12162	.60	Arm Distributor breaker	1	39-42	
352201-S		Cotter Pin	1	39-42	
351260-S		Washer	1	39-42	
91A-12174	.02	Washer - Dist. Breaker Plate Screw	1	39-42	
34803-S7-8		Washer (Lock) - Distributor Breaker Plate Bolt	1	39-42	
350101-S7-8		Bolt - Dist. Breaker Plate	1	39-42	
9N-12187	3.60	Shaft Cam and Weights Assy. Distributor	1	39-42	
91A-12200	.55	Rotor Assy. - Distributor	1	39-42	
B-12213	.01	Washer - Dist. Cam Screw	1	39-42	
68-12219	.30	Bracket Assy. - Dist. Contact	1	39-42	
68-12230	.03	Dist. Bracket Lock Screw	1	39-42	
9N-12250-B	.40	Resistor	1	39-42	
9N-12281-B	4.40	Conduit and Wiring Assy.	1	39-42	
9N-12281-C	4.30	Conduit and Wiring Assy.	1	39-42	
9N-12281-E	4.00	Conduit and Wiring Assy.	1		
9N-12283	.20	Wire (Cylinder No. 3) - Dist. to Spark Plug	1	39-42	
9N-12284	.20	Wire (Cylinder No. 2) - Dist. to Spark Plug	1	39-42	
9N-12286	.25	Wire (Cylinder No. 4) - Dist. to Spark Plug	1	39-42	
9N-12287	.20	Wire (Cylinder No. 1) - Dist. to Spark Plug	1	39-42	
91A-12300	.35	Condenser Assy.	1		
31032-S7		Screw - Condenser to Dist. Body	1	39-42	
34802-S7-8		Washer (Lock) - Condenser to Dist. Body Screw	1	39-42	
9N-12405	*.65 (Lots of 4 *.59)	Spark Plug Assy.	4	39-42	
52-12410	.01	Gasket - Spark Plug	4	39-42	

WIRING

(See Illustration on Page 33)

9N-13076	.35	Wire Assy. - Headlight Socket	2	39-42	
9N-13603	.30	Wire - Conduit to Indicator Lamp (Use With 9N-12281-D)	1	39-42	
9N-14300-A	.50	Cable Assy. - Battery to Switch	1	39-42	
9N-14300-C	1.20	Cable Assy. - Battery to Switch	1	39-42	
9N-14301	.60	Connector Assy. - Battery to Ground	1	39-42	
23017-S16		Bolt (Hex Head) - Battery Connection	2	39-42	
33797-S7-8		Nut (Hex) - Battery Connection	2	39-42	
9N-14377	.10	Connector Assy.	1	39-42	
9N-14401		Conduit and Wiring Assy. Distributor to Spark Plug	1	39-42	
9N-14431-A	.90	Cable Assy. - Starter Switch to Starter	1	39-42	
9N-14431-B	.60	Cable Assy. - Starter Switch to Starter	1	39-42	
51-14550	.10	Switch to Starter Cable Support Assy.	1	39-42	
9N-14564	.07	Bracket - Spark Plug Wire	1	39-42	
B-14585	.02	Clip		39-42	
B-14586	.02	Clip		39-42	
9N-2279	.05	Clip, Wiring, Right Side Ignition Switch.	1	39-42	

*Not subject to regular discount.



FORD TRACTOR PARTS PRICE LIST

Part No.	Price	Part Name	Unit	Year	Remarks
FENDER					
9N-16312	\$10.65	Fender Assy.	2	39-42	
21191-S7		Bolt (Hex Head) - Fender Bracket to Rear Axle Housing	4	39-42	
33806-S7-8-18		Nut (Hex) - Rear Fender Bracket to Rear Axle	4	39-42	
351505-S7-8		Washer (Flat) - Fender to Rear Axle Housing	4	39-42	

HOOD ASSEMBLY (See Illustration on Page 28)

9N-16600	.35	Ornament - Hood	1	39-42	
33795-S8		Nut (Hex) - Name Plate to Hood Top	1	39-42	
350835-S7		Nut (Speed) - Name Plate to Hood Top	1	39-42	
9N-16612-B	32.50	Top Assy. - Hood (Painted)	1	39-42	
9N-16612-C	32.50	Top Assy. - Hood (Painted)	1	39-42	
350472-S7		Bolt (Special Carriage) - Instrument Panel to Hood Top	4	39-42	
33798-S7-8		Nut - (Hex) - Instrument Panel to Hood Top Bolt	4	39-42	
34806-S7-8		Washer - Lock, - Instrument Panel to Hood Top Bolt	4	39-42	
9N-16618	1.90	Panel Assy. (Side) - Hood (R.H.)	1	39-42	
9N-16619	1.90	Panel Assy. (Side) - Hood (L.H.)	1	39-42	
20318-S7		Bolt (Hex Head) - Hood Side to Radiator Grille Lower Support	4	39-42	
34806-S7-8		Washer (Lock) - Hood Side to Support Bolt	4	39-42	
20311-S7		Bolt (Hex Head) - Hood Top to Hood Side Rear	4	39-42	
33798-S7-8		Nut (Hex) - Hood Top to Hood Side Bolt ..	4	39-42	
34806-S7-8		Washer (Lock) - Hood Top to Hood Side ...	4	39-42	
20311-S7		Bolt (Hex Head) - Hood Side to Support Lower Bracket	2	39-42	
34806-S7-8		Washer (Lock) - Hood Side to Support Radiator Bracket Bolt	2	39-42	
33798-S7-8		Nut (Hex) - Hood Side to Support Lower Bracket Bolt	2	39-42	
9N-16625	.60	Stud and Handle - Hood Top Battery	1	39-42	
33795-S7		Nut (Hex) - Hood Top Battery Cover Handle Stud	1	39-42	
34805-S7		Washer (Lock) - Hood Top Battery Cover Handle Stud	1	39-42	
9N-16651	.12	Retainer - Hood Top Battery Cover Hinge .	1	39-42	
63345-S7		Rivet (Oval Head) - Hood Top Battery Cover Hinge Retainer to Hinge	2	39-42	
9N-16656	.30	Tongue - Hood Top Battery Cover	1	39-42	
9N-16689	.30	Hinge - Hood Top Battery Cover	1	39-42	
60894-S7		Rivet (Oval Head) - Hood Top Battery Cover to Hinge	4	39-42	
9N-16938-B	.90	Cover Assy. - Hood Top Battery	1	39-42	
9N-16938-C	1.30	Cover Assy. - Hood Top Battery	1	39-42	
9N-16938-D	1.15	Cover Assy. - Hood Top Battery (Use with "C" Hood when repl. "A" and "B" Hoods) .	1	39-42	
9N-16942-C	.45	Cover - Hood Top Battery	1	39-42	
9N-16948-B	.08	Spring - Battery Opening Cover	4	39-42	

FORD TRACTOR PARTS PRICE LIST



Part No.	Price	Part Name	Unit	Year	Remarks
TOOL BOX AND TOOLS					
9N-17004	\$ 4.60	Tool Kit	1	39-42	
B-17005-A	.20	Tool Bag	1	39-42	
9N-17005	2.70	Tool Box Assy.	1	39-42	
21440-S7-8		Bolt (Hex Head) - Tool Box to Upper Housing	2	39-42	
351436-S7-8		Washer (Lock) - Tool Box	2	39-42	
9N-17014	.75	Wrench (Open End-Hex)	1	39-42	
01A-17015	.20	Wrench (Open End-Hex)	1	39-42	
01A-17016	.20	Wrench (Open End-Hex)	1	39-42	
01A-17017-B	.45	Wrench - Spark Plug and Cylinder Head Nut	1	39-42	
B-17020	.20	Screw Driver	1	39-42	
01A-17021	.55	Wrench - Monkey	1	39-42	
B-17025-A	.30	Pliers Assy.	1	39-42	
9N-17040	.65	Crank - Starting	1	39-42	
9N-17081	.50	Handle - Jack	1	39-42	
9N-17125-B	1.10	Grease Gun	1	39-42	
9N-17667	.10	Clip - Wiring	1	39-42	
9N-17668	.06	Clip - Wiring	3	39-42	

GOVERNOR

(See Illustration on Page 29)

9N-18200-B	16.25	Governor Assy.	1	39-42	
20488-S7		Bolt (Hex Head) - Governor to Side Cover.	1	39-42	
88032-S		Stud (Screw) - Governor to Side Cover ...	1	39-42	
33800-S7-8		Nut (Hex) - Governor to Side Cover	1	39-42	
34807-S7-8		Washer (Lock) - Governor to Side Cover ..	2	39-42	
9N-18185	4.25	Body Assy. - Governor	1	39-42	
9N-18186	2.30	Lower Race Assy. - Governor	1	39-42	
9N-18187	2.60	Drive Shaft Assy. - Governor	1	39-42	
9N-18188	.50	Upper Race Assy. - Governor	1	39-42	
9N-18189	1.60	Lever Assy. - Governor	1	39-42	
9N-18190	1.10	Manual Lever Assy. - Governor	1	39-42	
22612-S7		Screw - Adjusting	1	39-42	
33921-S7		Nut - Adjusting Screw	1	39-42	
34825-S8		Washer (Lock) - Adjusting Screw	1	39-42	
9N-18191	1.00	Base - Governor	1	39-42	
9N-18192	.30	Bearing - (Thrust) - Governor Base	1	39-42	
9N-18194	.30	Base (Fork) - Governor	1	39-42	
9N-18195	.02	Clip - Governor Shaft	1	39-42	
9N-18196	.20	Spring - Governor Base	1	39-42	
9N-18215-C	1.00	Pipe - Air Cleaner to Carburetor	1	39-42	
9N-18241	.01	Shim - Ball Stop	As Req.	39-42	
355027-S7		Screw - Governor Body	2	39-42	
356430-S		Washer - Ball Stop	1	39-42	
358081-S		Ball - Governor Base	4	39-42	
356490-S		Spacer, Governor Drive Shaft	1	39-42	
357408-S		Pin, Governing Lever Link	1	39-42	
357409-S		Pin, Manual Lever Link	1	39-42	

OIL FILTER

(See Illustration on Page 29)

9N-18658	3.00	Oil Filter Assy.	1	39-42	
358043-S7-8		Plug - Oil Filter	1	39-42	
20348-S7-8		Bolt (Hex Head) - Oil Filter to Upper Housing	2	39-42	
351436-S7-8		Washer (Lock) - Oil Filter	2	39-42	
9N-18662	\$ 1.00	Element - Oil Filter	1	39-42	
9N-18666	.20	Tube - Oil Filter Outlet	1	39-42	
9N-18667	.20	Tube - Oil Filter Inlet	1	39-42	
91A-2133	.03	Nut - Oil Filter Inlet Tube	4	39-42	



FORD TRACTOR PARTS PRICE LIST

Part No.	Price	Part Name	Unit	Year	Remarks
OIL FILTER (CONT'D)					
9N-18668	.20	Elbow - Filter and Gauge to Block	1	
01A-18675	.03	Washer - Cover Hold Down Bolt	1	
9N-18676	.30	Tube - Oil Pressure Gauge	1	39-42	
9N-18677	.20	Oil Filter Cartridge Spacer	2	39-42	
9N-18678	.03	Nut - Oil Gauge Tube	1	39-42	
9N-18679	.06	Adapter - Oil Filter Tube	3	39-42	
9N-18685	.07	Adapter - Oil Gauge Tube	1	39-42	
9N-18686	.10	Elbow - Oil Filter	1	39-42	
9N-18687	1.20	Cover - Oil Filter	1	39-42	
9N-18688	.10	Gasket - Oil Filter Cover	1	39-42	
01A-18689	.20	Spring and Washer (Hold Down) - Element .	1	39-42	
01A-18691-A	.30	Bolt - Oil Filter Cover	1	39-42	

HEAD LAMP

9N-11652	.85	Switch Assy. - Lighting with Connector Wires Assy.....	1	39-42	
9N-11653-B	2.25	Wiring - Lighting Assy. (Less Switch) ...	1	39-42	
9N-13002	4.50	Head Lamp Assy. R. H.	1	39-42	
9N-13003	4.50	Head Lamp Assy. L. H.	1	39-42	
356083-S7-8		Nut (Hex) - Head Lamp Assy.	2	39-42	
34809-S7-8		Washer (Lock) - Head-Lamp Assy.	2	39-42	
9N-13007	** .27	Bulb (32 C. P. 6-8 Volt) - Head Lamp	2	39-42	
9N-13045	.85	Door - Head Lamp Assy.	2	39-42	
9N-13060	.75	Lens - Head Lamp	2	39-42	
9N-13061	.05	Spring - Head Lamp Lens Assy.		39-42	
9N-13102	.30	Reinforcement - Medallion	2	39-42	
9N-13404	2.30	Lamp and Bracket Assy. - Rear	1	39-42	
33792-S7-8-18		Nut (Hex) - Tail Lamp Bracket	1	39-42	
34808-S4		Washer (Lock) - Tail Lamp Bracket	1	39-42	
9N-13445	.20	Lens (White) - Tail Lamp License Plate ..	1	39-42	
9N-13448	.40	Door - Rear Lamp	1	39-42	
9N-13450	.35	Lens (Red) - Rear Lamp	1	39-42	
B-13466	** .07	Bulb (6 Volt 3 C.P.) - Indicator Lamp ...	1	39-42	
9N-13468	.60	Bracket - Tail Lamp Support	1	39-42	
9N-13470	.35	Bracket - Fender Lamp R.H.	1	39-42	
9N-13471	.35	Bracket - Fender Lamp L.H.	1	39-42	
9N-13472	.65	Bracket - Lamp Mounting R.H.	1	39-42	
9N-13473	.65	Bracket - Lamp Mounting L.H.	1	39-42	
9N-14487	.02	Connector - Assy. - Wire	4	39-42	

ACCESSORIES

9N-755		Power Take Off Guard	1	39-42	
9N-760	*36.25	Power Take Off and Pulley Assy.	1	39-42	
9N-1170-D		Rear Wheels (Steel) - Pair	1	39-42	
	2.25	Paint - Tractor Gray (1/2 gal.)		39-42	
M-2888	4.15	Paint - Tractor Gray (1 gal.)		39-42	
	17.50	Paint - Tractor Gray (5 gals.)		39-42	
9N-17049	12.00	Cover - Tractor	1	39-42	
9N-17052	**4.25	Tire Pump	1	39-42	
9N-17078	3.70	Jack, Base and Handle Assy.	1	39-42	
9N-17080	3.05	Jack and Base	1	39-42	
9N-18438	16.45	Kit - Lighting	1	39-42	

* Not subject to regular discount.
**See Bulletin for special price.

STANDARD PARTS

Part No.	Price	Part Name	Part No.	Price	Part Name
20302-S7-8	\$.01	5/16-18 x 3/8	21182-S7	.20	5/8-18 x 2.875
	.70-C	Hex Head Bolt		1.80-X	Hex Head Bolt
20305-S7-8	.01	1/4-28 x 7/16	21191-S7	.20	5/8-18 x 5.312
	.60-C	Hex Head Bolt		18.25-C	Hex Head Bolt
20306-S7	.02	5/16-18 x 7/16	21192-S7	.20	5/8-18 x 5.69
	1.35-C	Hex Head Bolt		1.80-X	Hex Head Bolt
20310-S7	.01	5/16-18 x 1/2	21440-S7	.03	7/16-14 x .75
	.80-C	Hex Head Bolt		2.30-C	Hex Head Bolt
20311-S7	.01	5/16-24 x 1/2	21441-S7	.03	7/16-1.4 x 1.128
	.80-C	Hex Head Bolt		2.65-C	Hex Head Bolt
20318-S7	.01	5/16-18 x 9/16	21442-S7	.04	7/16-14 x 1.38
	.75-C	Hex Head Bolt		3.00-C	Hex Head Bolt
20319-S7	.02	5/16-24 x 9/16	21443-S7	.03	7/16-14 x .94
	1.15-C	Hex Head Bolt		2.60-C	Hex Head Bolt
20325-S7	.02	1/4-28 x 5/8	21445-S7	.04	7/16-14 x 1.38
	1.10-C	Hex Head Bolt		3.00-C	Hex Head Bolt
20346-S7	.01	5/16-18 x 3/4	21446-S7	.05	7/16-14 x 2.5
	.90-C	Hex Head Bolt		3.75-C	Hex Head Bolt
20347-S7	.01	5/16-24 x 3/4	21449-S7	.06	7/16-14 x 3.625
	.80-C	Hex Head Bolt		.90-XX	Hex Head Bolt
20348-S7	.02	3/8-16 x 3/4	21477-S7	.02	5/16-18 x 1-5/8
	1.25-C	Hex Head Bolt		1.00-C	Hex Head Bolt
20356-S7	.01	5/16-18 x 13/16	22228-S7	.05	5/16-24 x 1-1/4
	.75-C	Hex Head Bolt		4.00-C	Hex Head Bolt
20366-S2	.01	5/16-18 x 7/8	22267-S7	.05	7/16-20 x 1-3/4
	.85-C	Hex Head Bolt		4.50-C	Hex Head Bolt
20368-S7	.02	3/8-16 x 7/8	22503-S	.04	1/4-20 x 5/8
	1.30-C	Hex Head Bolt		3.50-C	Hex Head Bolt
20386-S2	.01	5/16-18 x 1	22612-S7-8	.08	1/4-28 x 3/4
	.90-C	Hex Head Bolt		.02	Hex Head Bolt
20388-S2	.02	3/8-16 x 1	23017-S16	1.25-C	5/16-18 x 1-1/4
	1.60-C	Hex Head Bolt		.01	Hex Head Bolt
20389-S	.02	3/8-24 x 1	23423-S7	.70-C	5/16-18 x 1-5/8
	1.40-C	Hex Head Bolt		.01	Hex Head Bolt
20408-S7	.02	3/8-16 x 1	24327-S7	.60-C	5/16-24 x 5/8
	1.45-C	Hex Head Bolt		.01	Hex Head Bolt
20426-S7	.01	5/16-18 x 1-1/4	24642-S7	.65-C	5/16-18 x 9/16
	.95-C	Hex Head Bolt		.01	Flat Head Screw
20488-S7	.02	3/8-16 x 1-5/8	25231-S7	.01	No. 10-32 x 1/2
	1.50-C	Hex Head Bolt		.60-C	Flat Head Screw
20559-S	.05	1/2-20 x 3-1/4	25881-S	.01	No. .8-32 x 5/8
	4.50-C	Hex Head Bolt		.45-C	Brass Flat Head Screw
20672-S	.04	9/16-12 x 1-1/4	26456-S7	.01	No. 6-32 x 1/4
	3.10-C	Hex Head Bolt		.40-C	Round Head Screw
20873-S7-8	.07	7/16-20 x 1.06	27153-S7	.01	No. 10-32 x 1-1/8
	1.10-XX	Hex Head Bolt		.55-C	Round Head Screw
20874-S7-8	.03	7/16-20 x .68	27161-S7	.01	No. 10-32 x 1-1/4
	2.60-C	Hex Head Bolt		.65-C	Round Head Screw
20876-S7-8	.07	7/16-20 x .88	31027-S7	.01	No. 8-32 x 3/16
	1.10-XX	Hex Head Bolt		.35-C	Head Screw
20878-S7-8	.05	7/16-20 x 1.25	31032-S7	.01	Fillister
	4.00-C	Hex Head Bolt		.35-C	No. 8-32 x 1/4
20879-S7		7/16-20 x 1.75	31061-S7	.01	Head Screw
	.04	Hex Head Bolt		.40-C	Fillister
20880-S7-8	3.00-C	7/16-20 x 1.38	31588-S7	.01	No. 8-32 x 1/2 Head
	.04	Hex Head Bolt		.60-C	Screw Fillister
20881-S7-8	3.45-C	7/16-20 x 1.56	33790-S7-8	.02	No. 10-32 x 5/16
	.04	Hex Head Bolt		.02	Head Screw
20882-S7-8	3.40-C	7/16-20 x 1.375	33791-S7-8-18	.02	Fillister
	.10	Hex Head Bolt		1.20-C	7/16-20
20886-S7-8	1.40-XX	7/16-20 x 3.32	33792-S7-8-18	.02	Hex Check Nut
	.05	Hex Head Bolt		1.80-C	7/16-20 Hex Nut
20887-S7	4.00-C	7/16-20 x 3		.03	7/16-20
	.10	Hex Head Bolt		2.65-C	Hex Nut
20889-S7	1.80-XX	7/16-20 x 5			
		Hex Head Bolt			



STANDARD PARTS

Part No.	Price	Part Name	Part No.	Price	Part Name
33794-S7-8	\$.02	7/16-20	34902-S7-8	\$.01	No. 8 Shake-proof
	1.70-C	Thick Hex Nut		.30-C	Washer
33795-S7	.01	1/4-20 Hex Nut	34906-S2	.01	5/16 Lock Washer
	.35-C			.25-C	
33797-S7-8	.01	5/16-18	60037-S	.01	3/16 x 7/16
	.65-C	Nut Reg Hex		.15-C	Rivet Flat Head
33798-S7-8	.01	5/16-24 Hex Nut	60319-S	.01	3/16 x 5/16
	.65-C			.10-C	Round Head Rivet
33800-S7-8	.01	3/8-24 Hex Nut	60530-S	.01	1/2 x 2 Rivet
	.90-C			.10-C	Round Head Solid
33806-S7-8-18	.05	5/8-18 Hex Nut	62201-S7-8	.01	1/8 x 3/8
	4.50-C			.15-C	Rivet - Flat Head
33816-S	.03	5/16-20 Hex Nut	72003-S7-8	.03-X	1/16 x 1/2
	3.15-C			.10-C	Cotter Pin
33817-S	.02	7/16-20 Slotted	72004-S	.02-X	3/32 x 1/2
	1.75-C	Nut (Thin)		.10-C	Cotter Pin
33825-S7-8	.03	5/16-18 Hex Nut	72005-S	.02-X	1/4 x 1/2
	2.00-C			.05-C	Cotter Pin
33860-S7	.10	5/8 x 18	72010-S	.03-X	1/8 x 5/8
	1.40-XX	Castle Nut		.10-C	Cotter Pin
33879-S7	.01	5/16 x 24 Hex Nut	72017-S	.03-X	1/8 x 3/4
				.10-C	Cotter Pin
33921-S7	.01	1/4-28 Check Nut	72026-S	.03-X	1/8 x 7/8
	.60-C			.10-C	Cotter Pin
33923-S7	.01	5/16-24 Check Nut	72035-S	.03-X	1/8 x 1 Cotter Pin
	.60-C			.10-C	
34029-S7-8	.02	5/16 x 24 Hex Nut	72036-S	.05-X	5/32 x 1 Cotter Pin
	1.50-C			.20-C	
34052-S7	.01	No. 8-32 Hex Nut	72054-S	.05-X	5/32 x 1-1/4
	.20-C			.20-C	Cotter Pin
34079-S7	.01	No. 10-32 Hex Nut	73902-S	.07	3/8 x 1 Clevis Pin
	.30-C			.04	3/8 x 1-1/16
34141-S7-8	.01	No. 10-32	73912-S7	3.40-C	Clevis Pin
	.20-C	Square Nut		.06	5/16 x 1-1/6
34171-S7-8	.05	5/16-24 Blind Nut	73918-S7		Clevis Pin
	4.00-C			.06	1/2 x 1-1/4 Clevis Pin
34703-S7	.01	No. 10 Washer Flat	73936-S7-8	.05	3/8 x 1-7/16
	.15-C			4.00-C	Clevis Pin
34706-S7-8	.01	5/16 Washer Flat	73956-S	.04	1/4 x 1-11/16
	.25-C			3.25-C	Clevis Pin
34745-S7-8	.01	1/4 Washer Flat	73984-S	.05	5/16 x 1-11/16
	.20-C			4.00-C	Clevis Pin
34746-S7-8	.01	5/16 Washer Flat	74034-S	.06	1/2 x 2-5/8 Clevis Pin
	.20-C			.01	5/16 Expansion Plug
34802-S7-8	.01	No. 10 Lock Washer	74079-S7-8	.70-C	
	.20-C			.01	1-3/16 Expansion
34803-S7-8	.01	No. 10 Lock Washer	74106-S	.70-C	Plug
	.15-C			.01	1-1/4 Expansion
34804-S2	.01	No. 12 Washer	74120-S	.70-C	Plug
	.15-C			.01	1-3/4 Expansion
34805-S7	.01	1/4 Lock Washer	74127-S	.75-C	Plug
	.20-C			.01	1/2 x 1/8
34806-S7-8	.01	5/16 Lock Washer	74142-S	.50	Woodruff Key
	.25-C			.04	1/4 x 1/8
34807-S7-8	.01	3/8 Lock Washer	74156-S	3.60-C	Woodruff Key
	.30-C			.01	No. 6 Woodruff Key
34809-S7-8	.01	1/2 Lock Washer	74175-S	.90-C	
	.55-C			.04	1/4 x 1-1/8
34810-S	.01	9/16 Lock Washer	74186-S	3.90-C	Woodruff Key
	.65-C			.03	3/8-24-16 x 1-3/8
34822-S7-8	.01	No. 8 Lock Washer	88032-S7	2.30-C	Stud
	.15-C			.04	7/16-20-14 x 2-3/8
34842-S7-8	.01	No. 8 Lock Washer	88113-S7	2.85-C	Stud
	.20-C			.02	5/16-24-18 x 2
			88146-S	1.80-C	Stud

STANDARD PARTS

Part No.	Price	Part Name	Part No.	Price	Part Name
88371-S	\$.02	5/16-24-18 x 1-1/4 Stud	351436-S7-8	\$.02	7/16 Spec
	1.20-C			1.30C	Lock Washer
88398-S	.04	7/16-20-14 Stud	351505-S7-8	.02	5/8 (5/32 x 1-1/4)
	3.00-C			1.75-C	Flat Washer
88403-S	.04	5/16-14-20 Stud	351544-S	.02	.815-.820
	2.85-C			1.60-C	Spec Lock Washer
88423-S	.04	7/16-20-14 x 1-7/8 Stud	351926-S	.01	5/32 x 3/16 Rivet
	3.10 C			.40-C	(Flat Head C'sunk)
88523-S	.03	7/16-20-14 x 3-1/8 Stud	351963-S	.01	3/16 x .94
	2.50-C			.35-C	Rivet
97013-S	.15	3/8 x 2-1/8 Clevis Adjustable	351978-S	.01	3/16 x 47
	.02	No. 10-32 x 1/2		.55-C	Special Rivet
350101-S7-8	1.25-C	Screw - Slotted	352150-S	.04	7/16 x 1-1/2
	.01	5/16x24x6.10		3.45-C	Rivet - Round Head
350400-S	.80-C	Hex Bolt	352201-S	.01	3/64 x .31
	.01	5/16-18 x 1		.15-C	Cotter Pin
350433-S	.80-C	Hex Screw	352250-S	.01	.110 x .68
	.02	Bolt		.10C	Cotter Pin
350439-S	1.40-C		352472-S7-8	.01	.120/.130 D Pin
	.01	5/16-24 x 5/8 Spec Carriage Bolt		.20C	
350472-S7-8	.70-C		352547-S	.05	.247 x .98
	.03	7/16 x 20 Bolt, Carriage, Spec		4.00-C	Clevis Pin
350617-S7-8	2.65-C		352581-S7-8	.01	5/16 x 1-1/2
	.10	7/16-20		.60-C	Spec Pin
350635-S7-8	9.00-C	Hex Bolt (Spec)	352592-S	.04	3/8 x 1-1/4
	.07	7/16-20 x .84		3.35-C	Clevis Pin
350645-S	6.50-C	Hex Head Bolt	352625-S7-8	.15	.750 x 2.9
	.15	3/8-18			Clevis Pin
350719-S7	2.90-XX	Round Head Bolt	353035-A1-S7-8	.14	1/4-28 Lubrication Fitting
	.02	No. 8-32 Nut	353043-A1-S7-8	.03	Lubrication Fitting
350830-S7-8	1.35-C		353043-A2-S7-8	.03	1/4-28 Lubrication Fitting
	.01	.18 Speed Nut		.03	
350835-S7	.70-C		353064-S	2.35-C	1/2 Pipe Plug
	.02	Brass No. 10-32 Hex Nut		.04	
350860-S	1.40-C		353075-S	3.20-C	3/8 Ball (Steel)
	.03	Wing, Nut - (Spec)		.01	
350923-S7-8	2.70-C		353076-S	.40-C	1/4 Steel Ball
	.02	7/16 x 20		.05	No. 4-36 x 1/4
351025-S7-8	1.85-C	Hex Head Nut	355000-S	4.50-C	Screw (Machine)
	.03	7/16-x 20		.01	No. 6-32 x .28
351040-S7-8	2.15-C	Hex Nut	355027-S	.40-C	Flat Head Screw
	.03	1/2 x 20		.02	3/8 x 16 x 1.25
351059-S7-8	2.50-C	Hex Slotted Nut	355545-S	1.40-C	Hex Bolt
	.25	5/8 x 18 Acorn Nut		.01	7/16-14 x 1-3/8
351103-S22	.05		355693-S7-8	.40-C	Spec Hex Bolt
	4.00-C	11/16 Spec Hex Nut		.05	1/4-20 Special
351118-S7-8	.04	13/16-28	355940-S7-8	4.50-C	Wing Nut
	3.60-C	Spec Hex Nut			1/2-20 Hex Nut
351119-S7	.08	3/4 x 16 Castle Nut	356083-S7-8	.07	No. 4 Lock Washer
	1.30-XX		356181-S	.02	Washer
351129-S	.01	No. 10 Lock Washer	356430-S	1.25-C	
	.15-C			.03	Spacer
351253-S7	.01	Plain Washer (Brass)	356490-S	2.20-C	
	.45-C		357408-S	.05	Pin
351260-S	.01	13/32 I.D. x 1-1/2 O.D. Spec	357724-S7	.07	Stud
	.70-C	Plain Washer	358043-S7	.12	1/8 Pipe Plug
351406-S7	.01	7/16-1/8x29/32 Washer	358081-S	.20	5/8 Ball
	.60-C				

WARRANTY

The Ford Motor Company warrants all such parts of new Ford tractors, **EXCEPT TIRES**, for a period of ninety (90) days from the date of original delivery to the purchaser of each new Ford tractor, as shall, under normal use and service, appear to it to have been defective in workmanship or material. This warranty shall be limited to shipment to the purchaser without charge, except for transportation, of the part or parts intended to replace those acknowledged by the Ford Motor Company to be defective. The Ford Motor Company cannot, however, and does not accept any responsibility in connection with any of its tractors when they have been altered outside of its own factories or branch plants. If the purchaser shall use or allow to be used in the tractor, parts not made or supplied by the Ford Motor Company, then this warranty shall become void. The Ford Motor Company does not undertake responsibility to any purchaser of its products for any undertaking, representation or warranty made by anyone selling its products beyond those herein expressed.

The Ford Motor Company reserves the right to make changes in design and changes or improvements upon its product without imposing any obligation upon itself to install the same upon its products theretofore manufactured.

TIRE WARRANTY

Every tractor tire manufactured by the Ford Motor Company, bearing its name and serial number and used in farm service and agriculture, is warranted by it to be free from defects in workmanship and material without limit as to time or mileage and to give satisfactory service under normal operating conditions. If the Ford Motor Company's examination shows that any tire has failed under the terms of this warranty, it will at its option either repair the tire or make an allowance on the purchase of a new tire.

FORD MOTOR COMPANY

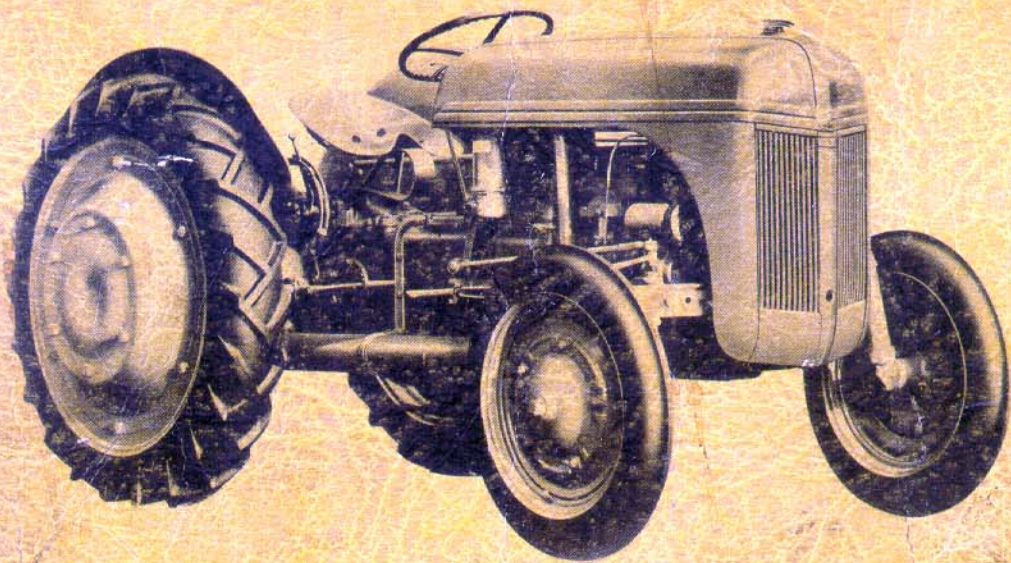

***"-Have it in the bin,
when the Farmer comes in."***